

JVC

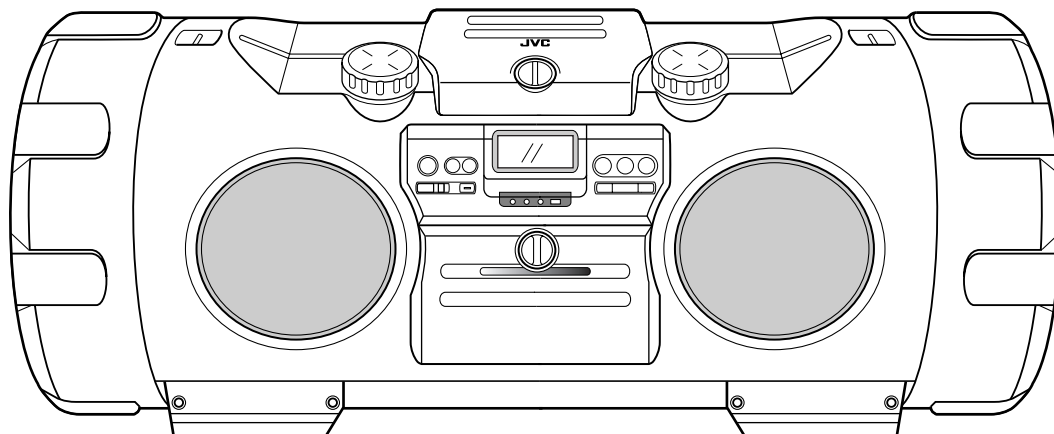

POWERED WOOFER CD SYSTEM

RV-NB10B/RV-NB10W

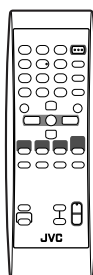
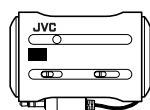

MP3
PLAYBACK

COMPACT
disc
DIGITAL AUDIO

INSTRUCTIONS

For Customer Use:

Enter below the Model No. and Serial No. which are located either on the rear, bottom or side of the cabinet. Retain this information for future reference.

Model No. _____

Serial No. _____

LVT1539-001A

[J]

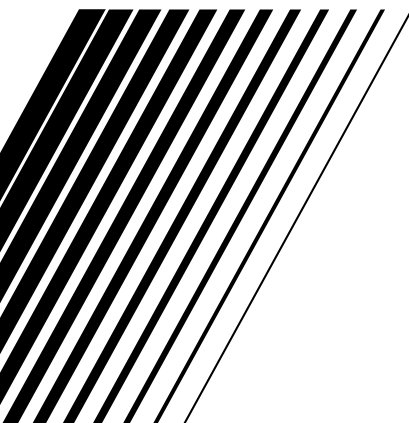

Warnings, Cautions and Others

Mises en garde, précautions et indications diverses

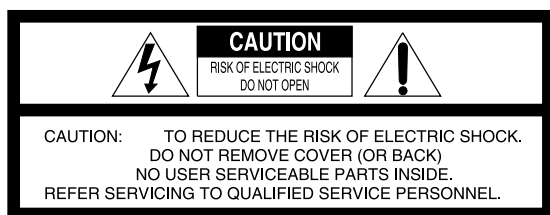

The lightning flash with arrowhead symbol, within an equilateral triangle is intended to alert the user to the presence of uninsulated "dangerous voltage" within the product's enclosure that may be of sufficient magnitude to constitute a risk of electric shock to persons.



The exclamation point within an equilateral triangle is intended to alert the user to the presence of important operating and maintenance (servicing) instructions in the literature accompanying the appliance.

WARNING: TO REDUCE THE RISK OF FIRE OR ELECTRIC SHOCK, DO NOT EXPOSE THIS APPLIANCE TO RAIN OR MOISTURE.

CAUTION— ON/STANDBY button!

Disconnect the mains plug to shut the power off completely (the STANDBY lamp goes off). When installing the apparatus, ensure that the plug is easily accessible. The  ON/STANDBY button in any position does not disconnect the mains line.

- When the unit is on standby, the STANDBY lamp lights red.
- When the unit is turned on, the STANDBY lamp goes off.

The power can be remote controlled.

ATTENTION—Touche ON/STANDBY!

Déconnectez la fiche secteur pour mettre l'appareil complètement hors tension (le témoin STANDBY s'éteint). Lors de l'installation de l'appareil, assurez-vous que la fiche soit facilement accessible. La touche  ON/STANDBY dans n'importe quelle position ne déconnecte pas l'appareil du secteur.

- Quand l'appareil est en mode d'attente, le témoin STANDBY est allumé en rouge.
- Quand l'appareil est sous tension, le témoin STANDBY s'éteint.

L'alimentation ne peut pas être commandée à distance.

CAUTION

To reduce the risk of electrical shocks, fire, etc.:

1. Do not remove screws, covers or cabinet.
2. Do not expose this appliance to rain or moisture.

ATTENTION

Afin d'éviter tout risque d'électrocution, d'incendie, etc.:

1. Ne pas enlever les vis ni les panneaux et ne pas ouvrir le coffret de l'appareil.
2. Ne pas exposer l'appareil à la pluie ni à l'humidité.

For U.S.A.

This equipment has been tested and found to comply with the limits for a Class B digital device, pursuant to part 15 of the FCC Rules. These limits are designed to provide reasonable protection against harmful interference in a residential installation. This equipment generates, uses, and can radiate radio frequency energy and, if not installed and used in accordance with the instructions, may cause harmful interference to radio communications. However, there is no guarantee that interference will not occur in a particular installation. If this equipment does cause harmful interference to radio or television reception, which can be determined by turning the equipment off and on, the user is encouraged to try to correct the interference by one of the following measures: Reorient or relocate the receiving antenna. Increase the separation between the equipment and receiver. Connect the equipment into an outlet on a circuit different from that to which the receiver is connected. Consult the dealer or an experienced radio/TV technician for help.

For wireless transmitter

This device complies with Part 15 of the FCC Rules. Operation is subject to the following two conditions:

- (1) This device may not cause harmful interference.
- (2) This device must accept any interference received, including interference that may cause undesired operation.

IMPORTANT NOTE:

FCC Radiation Exposure Statement:

This equipment complies with FCC RF radiation exposure limits set forth for an uncontrolled environment. To maintain compliance with FCC RF exposure compliance requirements, please avoid direct contact to the transmitting antenna during transmitting.

This transmitter must not be co-located or operating in conjunction with any other antenna or transmitter.

For Canada/pour le Canada

THIS DIGITAL APPARATUS DOES NOT EXCEED THE CLASS B LIMITS FOR RADIO NOISE EMISSIONS FROM DIGITAL APPARATUS AS SET OUT IN THE INTERFERENCE-CAUSING EQUIPMENT STANDARD ENTITLED "DIGITAL APPARATUS," ICES-003 OF THE DEPARTMENT OF COMMUNICATIONS.

CET APPAREIL NUMERIQUE RESPECTE LES LIMITES DE BRUITS RADIOELECTRIQUES APPLICABLES AUX APPAREILS NUMERIQUES DE CLASSE B PRESCRITES DANS LA NORME SUR LE MATERIEL BROUILLEUR: "APPAREILS NUMERIQUES", NMB-003 EDICTEE PAR LE MINISTRE DES COMMUNICATIONS.

Operation is subject to the following two conditions: (1) this device may not cause interference, and (2) this device must accept any interference, including interference that may cause undesired operation of the device.

L'utilisation de ce dispositif est autorisée seulement aux conditions suivantes : (1) il ne doit pas produire de brouillage et (2) l'utilisateur du dispositif doit être prêt à accepter tout brouillage radioélectrique reçu, même si ce brouillage est susceptible de compromettre le fonctionnement du dispositif.

IMPORTANT FOR LASER PRODUCTS

1. CLASS 1 LASER PRODUCT
2. **CAUTION:** Do not open the top cover. There are no user serviceable parts inside the unit; leave all servicing to qualified service personnel.
3. **CAUTION:** Visible and/or invisible class 1M laser radiation when open. Do not view directly with optical instruments.

IMPORTANT POUR PRODUITS LASER

1. PRODUIT LASER CLASSE 1
2. **ATTENTION:** N'ouvrez pas le couvercle supérieur. Il n'y a aucune pièce réparable par l'utilisateur à l'intérieur de l'appareil; confiez toute réparation à un personnel qualifié.
3. **ATTENTION:** Rayonnement laser visible et/ou invisible de classe 1M une fois ouvert. Ne pas regarder directement avec des instruments optiques.

CAUTION:

- Do not block the ventilation openings or holes. (If the ventilation openings or holes are blocked by a newspaper or cloth, etc., the heat may not be able to get out.)
- Do not place any naked flame sources, such as lighted candles, on the apparatus.
- When discarding batteries, environmental problems must be considered and local rules or laws governing the disposal of these batteries must be followed strictly.
- Do not expose this apparatus to rain, moisture, dripping or splashing and that no objects filled with liquids, such as vases, shall be placed on the apparatus.

ATTENTION:

- Ne bloquez pas les orifices ou les trous de ventilation. (Si les orifices ou les trous de ventilation sont bloqués par un journal, un tissu, etc., la chaleur peut ne pas être évacuée correctement de l'appareil.)
- Ne placez aucune source de flamme nue, telle qu'une bougie, sur l'appareil.
- Lors de la mise au rebut des piles, veuillez prendre en considération les problèmes de l'environnement et suivre strictement les règles et les lois locales sur la mise au rebut des piles.
- N'exposez pas cet appareil à la pluie, à l'humidité, à un égouttement ou à des éclaboussures et ne placez pas des objets remplis de liquide, tels qu'un vase, sur l'appareil.

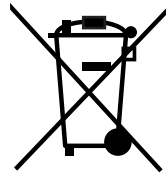

[European Union Only]
[Union européenne seulement]

Thank you for purchasing the JVC Powered Woofer CD System.

Before operating this system, read this manual carefully and thoroughly to obtain the best possible performance from your system, and retain this manual for future reference.

Features

Here are some of the things that make your system both powerful and simple to use.

■ General

- With JVC's **COMPU PLAY** you can turn on the system and automatically start the radio, disc player, or cassette deck with a single touch. (Only when AC power is used.)
- With the supplied wireless transmitter, you can listen to auxiliary equipment such as a digital audio player (not supplied) by wireless connection.
- Shoulder strap with carrying cases for the remote control and auxiliary equipment, and carrying handle
- ACS (Active Clear Sound) circuit for enhancing sound reproduction
- Super woofer volume control that provides powerful bass
- Sound mode control—reproducing various sound fields
- Remote control unit that operates the disc, cassette, tuner, and wireless functions
- Locking mechanism for disc and cassette door
- Microphone/guitar input



■ Disc playback mode includes Skip Play, Search Play, Repeat Play, Random Play, and Program Play.

■ Cassette player having full logic cassette mechanism, auto reverse, and auto tape mechanism.

■ A 45-station preset capability (30 stations in FM band and 15 stations in AM band) in addition to auto-seek and manual tuning.

■ Clock/timer functions, timer on/off with preset volume function, and sleep timer.

IMPORTANT CAUTIONS

1. Where to place the system

- Select a place which is level, dry and neither too hot nor too cold (between 5°C and 35°C or 41°F and 95°F).
- Leave sufficient distance between the system and a TV.
- Do not use the system in a place subject to vibrations.

2. Power cord

- Do not handle the power cord with wet hands!
- Some power is always consumed as long as the power cord is connected to the wall outlet.
- When unplugging the system from the wall outlet, always pull the plug, not the power cord.

3. When carrying the system

- Remove a disc from the system.
- Disconnect all the cords from the system.

4. Malfunctions, etc.

- There are no user serviceable parts inside. In case of system failure, unplug the power cord and consult your dealer.
- Do not insert any foreign object into the system.
- The system is not waterproof or dust proof.

Table of contents

Features	1	Listening to auxiliary equipment	16
IMPORTANT CAUTIONS	1	Transmitting sound on FM wave	16
Index of parts and controls	2	Connecting to the AUX IN jack	17
Getting started	3	Using the microphone/guitar	18
Basic operations	7	Using the timer	18
Listening to the radio	9	Care and maintenance	20
Playing back discs	10	Troubleshooting	21
Playing back tapes	13	Specifications	22
Recording	14		

Index of parts and controls

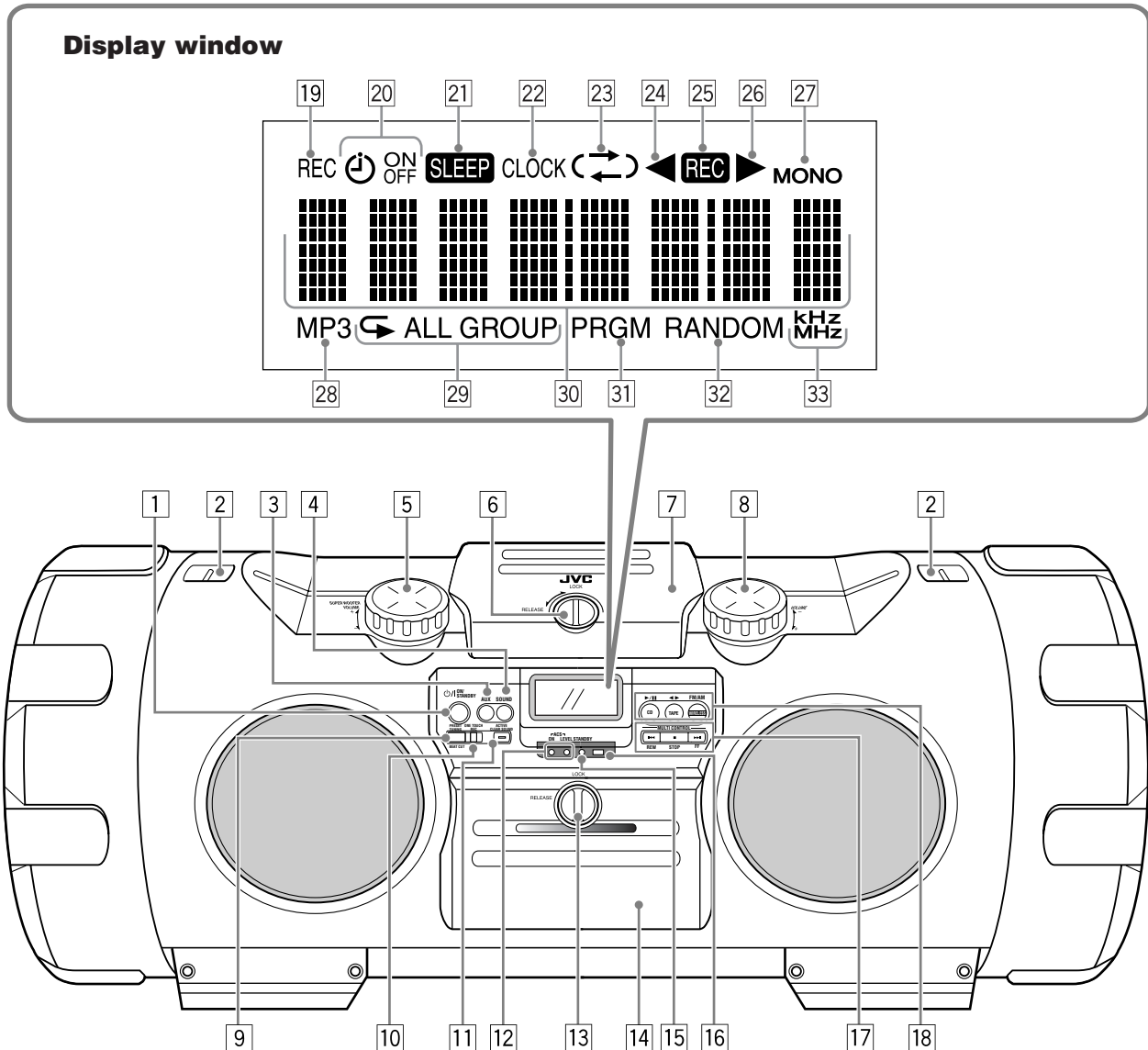

See pages in parentheses for details.

- 1 **⏻/ION/STANDBY** button (7)
- 2 Shoulder strap hooks (4)
- 3 **AUX** button (3, 17)
 - Pressing this button also turns on the unit.
- 4 **SOUND** button (8)
- 5 **SUPER WOOFER VOLUME +/-** control knob (8)
- 6 **LOCK/RELEASE** knob (for disc) (10)
- 7 Disc compartment door (10)
- 8 **VOLUME +/-** control knob (7)
- 9 **PRESET TUNING/BEAT CUT** button (9, 15 – 17)
- 10 **ONE TOUCH REC** button (15)
- 11 **ACTIVE CLEAR SOUND** button (8)
- 12 **ACS (Active Clear Sound)** indicators (8)
 - ON, LEVEL
- 13 **LOCK/RELEASE** knob (for deck) (13)
- 14 Cassette holder (13)
- 15 **STANDBY** indicator (7)
- 16 Remote sensor (4)
- 17 **MULTI CONTROL** buttons (9 – 15)
 - **⏮** REW (rewind), **■** STOP, **⏭** FF (fast-forward)
- 18 Source and play mode buttons (3, 9 – 17)
 - **CD** **▶/||**, **TAPE** **◀▶**, **WIRELESS/FM/AM**
 - Pressing one of these buttons also turns on the unit.

Display window

- 19 **REC** indicator (19)
- 20 **Timer** indicators (19)
 - **⏻** (timer), ON, OFF
- 21 **SLEEP** indicator (19)
- 22 **CLOCK** indicator (8, 18)
- 23 **↔** (reverse mode) indicator (13 – 15)
- 24 **◀** (reverse) tape direction indicator (13 – 15)
- 25 **REC** indicator (15)
- 26 **▶** (forward) tape direction indicator (13 – 15)
- 27 **MONO** indicator (9, 17)
- 28 **MP3** indicator (11)
- 29 **Repeat** indicators (12)
 - **↺**, ALL, GROUP
- 30 **Main display**
- 31 **PRGM** (program) indicator (12)
- 32 **RANDOM** indicator (12)
- 33 **Frequency unit** indicators (8 – 9)
 - kHz, MHz

Remote control

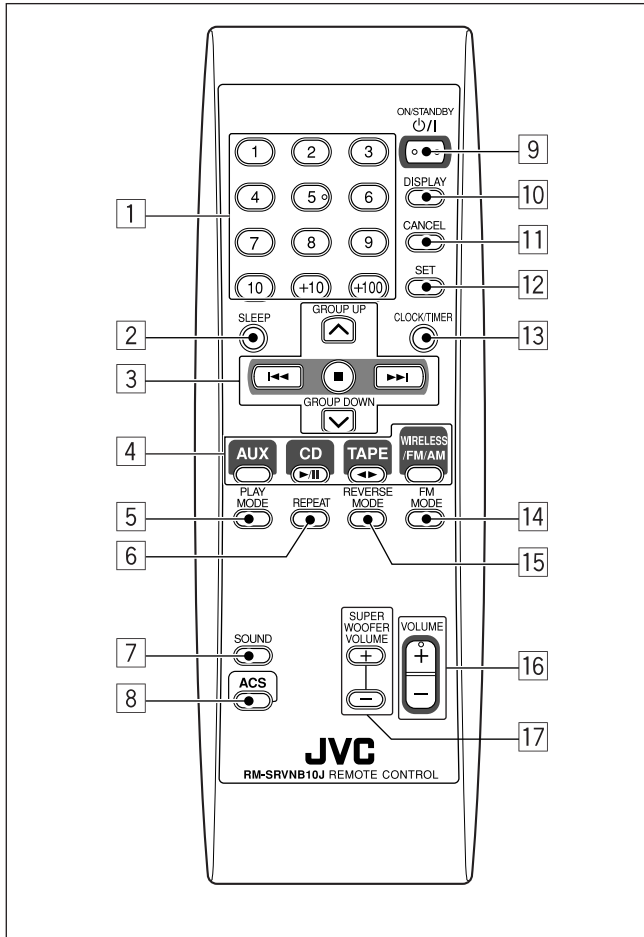

See pages in parentheses for details.

- 1 Number buttons (9, 11, 17)
- 2 SLEEP button (19)
- 3 Multi control buttons (9 – 15, 18 – 19)
 - ^ GROUP UP, v GROUP DOWN
 - ◀◀, ■, ▶▶
- 4 Source buttons (3, 9 – 17)
 - AUX, CD ▶/||, TAPE ◀▶, WIRELESS/FM/AM
 - Pressing one of these buttons also turns on the unit.
- 5 PLAY MODE button (12)
- 6 REPEAT button (12)
- 7 SOUND button (8)
- 8 ACS (Active Clear Sound) button (8)
- 9 ON/STANDBY button (7, 18 – 20)
- 10 DISPLAY button (8)
- 11 CANCEL button (12, 18 – 20)
- 12 SET button (10, 18 – 20)
- 13 CLOCK/TIMER button (18 – 20)
- 14 FM MODE button (9, 17)
- 15 REVERSE MODE button (13)
- 16 VOLUME +/- button (7)
- 17 SUPER WOOFER VOLUME +/- buttons (8)

COMPU PLAY — One Touch Operation

With One Touch Operation you can play a disc, a tape, or turn on the radio with a single press of the play button for that function. The system turns on and starts playing the source if it is ready.

The COMPU PLAY buttons are: **On the system and remote control**

- CD ▶/|| button
- TAPE ◀▶ button
- WIRELESS/FM/AM button
- AUX button

Note: The COMPU PLAY feature is not effective when the system is operated on batteries or car battery (DC12V).

Getting started

Accessories

Check that you have all the following items, which are supplied with the system.

- Power cord (1)
- Remote control (1)
- Shoulder strap with carrying cases for the remote control and auxiliary equipment (1)
- Wireless transmitter (1)
- Batteries*—R6(SUM-3)/AA(15F) (4)
- *Supplied batteries are for the initial setup for the remote control and wireless transmitter.

If any of these items are missing, contact your dealer immediately.

Carrying the system

■ Using the carrying handles

Be sure to hold both handles when you carry the system. If you carry the system by only one handle, because of the length of the system, the end may drag on the ground and be damaged as a result. Do not lift the system by the woofer ducts, and do not insert any foreign objects into them.

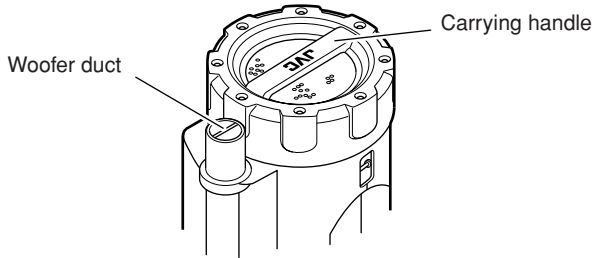

■ Using the shoulder strap

Attach the supplied shoulder strap (adjustable in length) to each end of the system as illustrated.

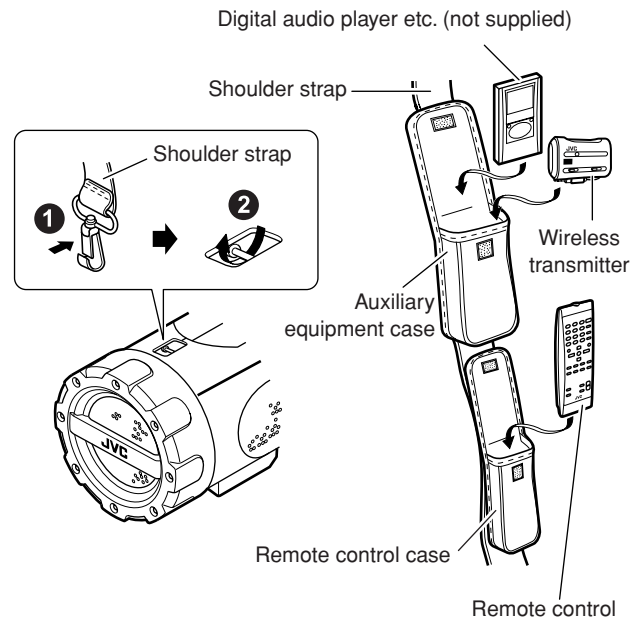

To detach the shoulder strap, press in the metal fitting and unhook it from the shaft.

Using the remote control — RM-SRVNB10J

■ Installing the batteries

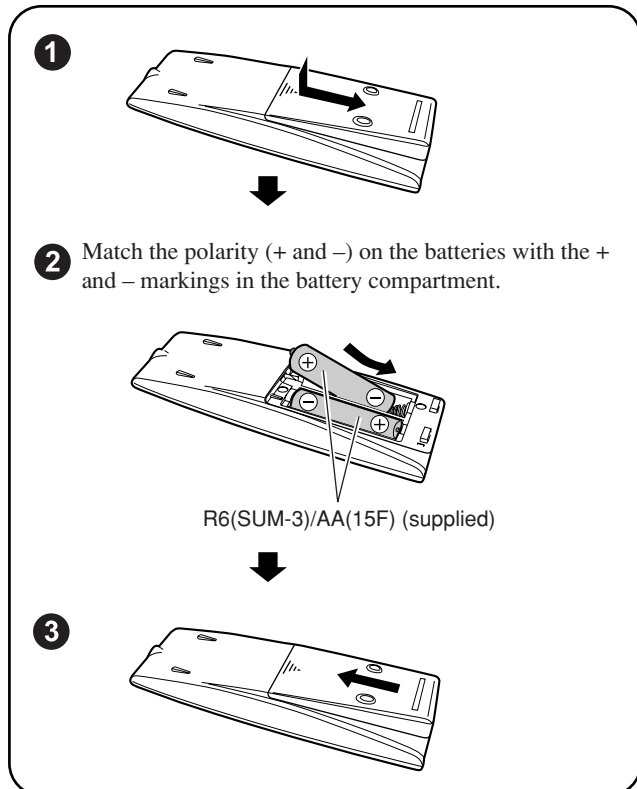

CAUTION:

To avoid battery leakage or explosion:

- Remove batteries when the remote control is not in use for an extended period of time.
- When you need to replace the batteries, replace both batteries at the same time with new ones.
- Do not use different types of batteries together.

Point the remote control at the remote sensor on the system's control panel (from a distance of up to 7 m or 23 feet). If you point the remote control from the slant direction, the distance will be shortened.

- Do not expose the remote sensor to strong direct sunlight or artificial lighting.
- Make sure there are no obstacles between the remote sensor and the remote control.

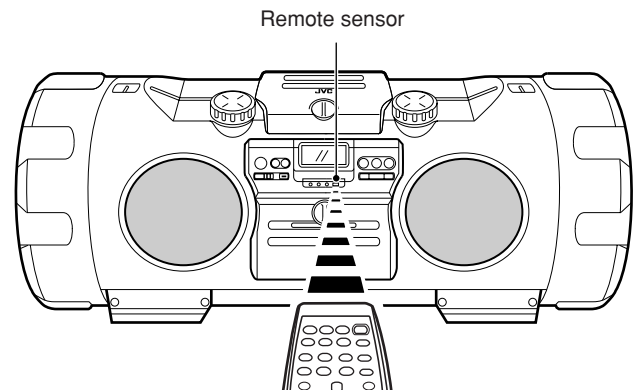

Connections

CAUTION: Make all connection before plugging the system into an AC power outlet.

■ Wireless connection (See page 16.)

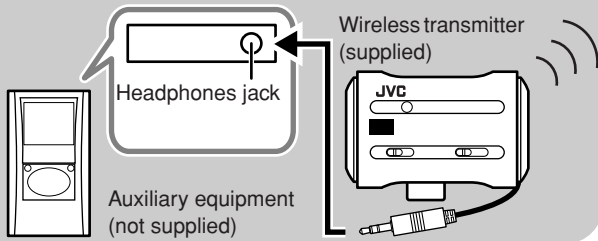

■ Connecting the auxiliary equipment (See page 17.)

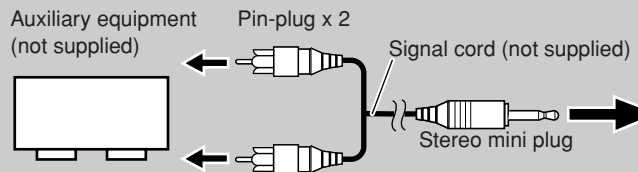

■ Connecting the microphone/guitar (See page 18.)

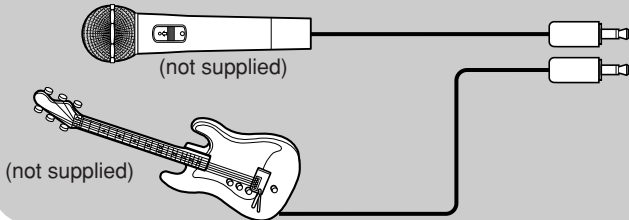

■ Connecting to the car battery

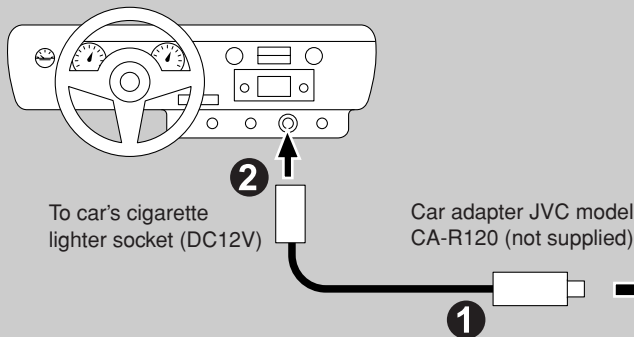

CAUTION:

- Be sure to use the specified car adapter (JVC model CA-R120) to prevent mishaps or damage resulting from different polarity design.
- For safety, stop the car before performing operations.
- Be sure to start the engine when you use the car adapter; otherwise, the car battery will be exhausted.
- During transport, stabilize the system in a box, etc.
- To prevent malfunctions, do not leave the system in a car for a long time.
- If the power is supplied through the car battery, the display will be blank with the system turned off (at standby).

Unplug the AC power cord from the system to supply the power through the car battery; otherwise, the system does not work.

■ Connecting the AC power cord

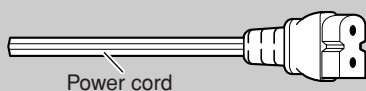

CAUTIONS:

- **ONLY USE THE JVC POWER CORD PROVIDED WITH THIS SYSTEM TO AVOID MALFUNCTION OR DAMAGE TO THE SYSTEM.**
- **BE SURE TO UNPLUG THE POWER CORD FROM THE OUTLET WHEN GOING OUT OR WHEN THE SYSTEM IS NOT IN USE FOR AN EXTENDED PERIOD OF TIME.**

■ Memory backup batteries

1

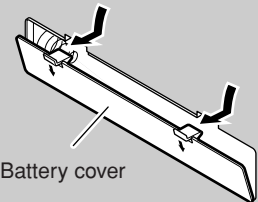

2

- Match the polarity (+ and -) on the batteries with the + and - markings in the battery compartment.

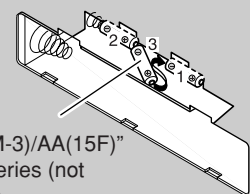

3

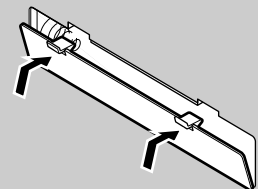

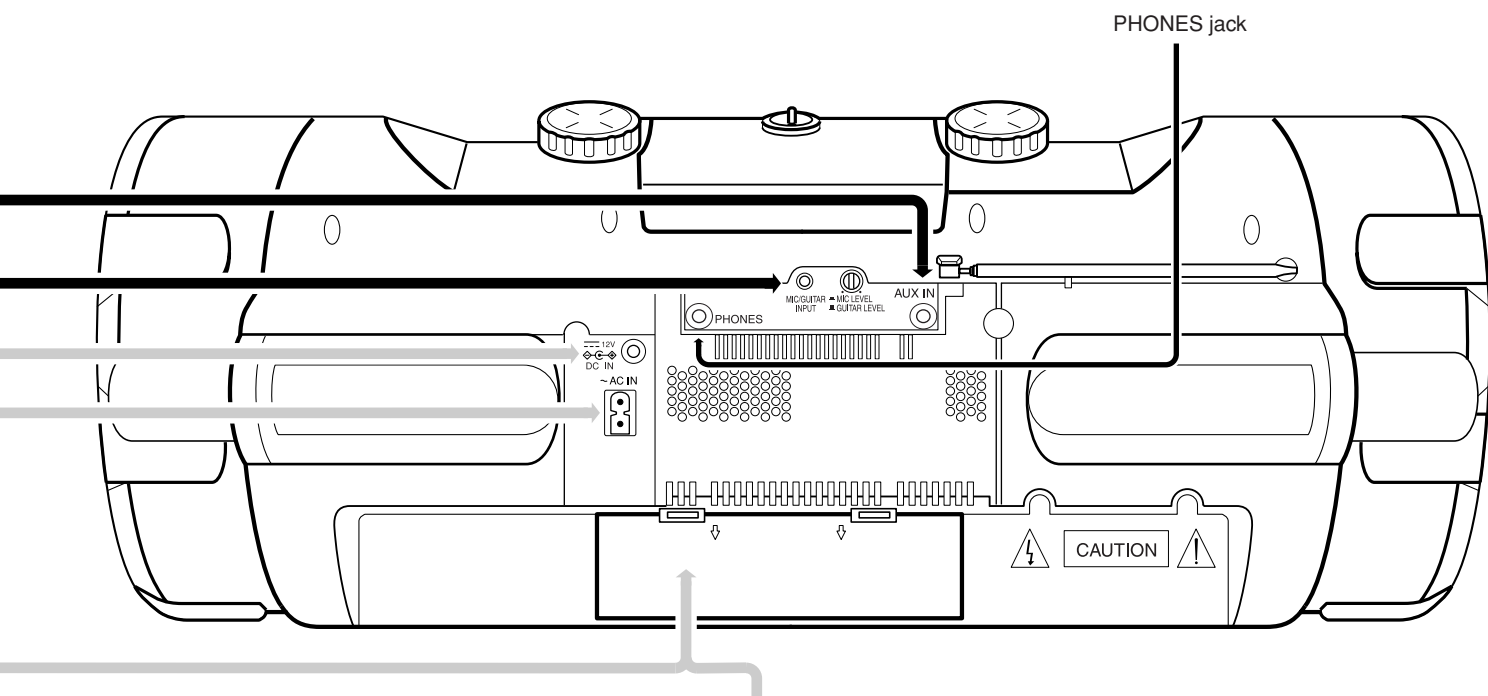

To remove the batteries, remove battery “3” first.

Notes:

- The memory backup batteries will not be consumed as long as the power is supplied from an AC outlet, loaded 10 batteries, or car battery (DC12V). However, if no power is supplied to the system, the memory backup batteries should be replaced with new ones approximately every 12 months to securely maintain the contents of the memory.
- Before replacing the memory backup batteries, always connect the AC power cord to the system to prevent the contents of memory from being erased.
- When a power failure occurs, the time indication disappears from the display to save the battery power of the memory backup batteries.

CAUTION:

- To avoid battery leakage or explosion:
- When you need to replace the batteries, replace all batteries at the same time with new ones. Before replacing, you need to supply AC power to the system.
 - Do not use an old battery with new ones.
 - Do not use different types of batteries together.

■ **Operating the system on batteries**

1

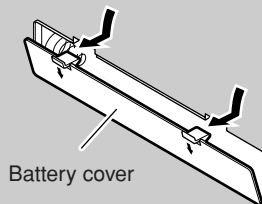

Battery cover



2

Match the polarity (+ and -) on the batteries with the + and - markings in the battery compartment.

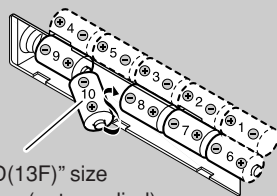

“R20/D(13F)” size batteries (not supplied)



3

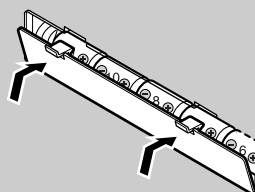

To remove the batteries, remove battery “10” first.

Notes:

- When you operate the system on mains (AC) power or on car battery (DC12V), the power source automatically switches from batteries to AC or DC12V. However, you should remove the 10 batteries when operating on AC power or car battery (DC12V).
- When the batteries are exhausted, the following symptoms will occur:
 - Mistracking occurs during disc playback.
 - Sounds are distorted intermittently during tape playback.
 - “DC OFF” flashes on the display, then the power goes off.
 If this happens, replace the batteries.
- It is recommended to use AC power cord when recording important material or listening to a disc.

CAUTION:

- To avoid battery leakage or explosion:
- Remove the 10 batteries when the system is not in use for an extended period of time.
 - When you need to replace the batteries, replace all batteries at the same time with new ones.
 - Do not use different types of batteries together.
 - If the power is supplied through the batteries, the display will be blank with the system turned off (at standby).

Unplug the AC power cord from the system to supply the power through the batteries; otherwise, the system does not work.

Basic operations

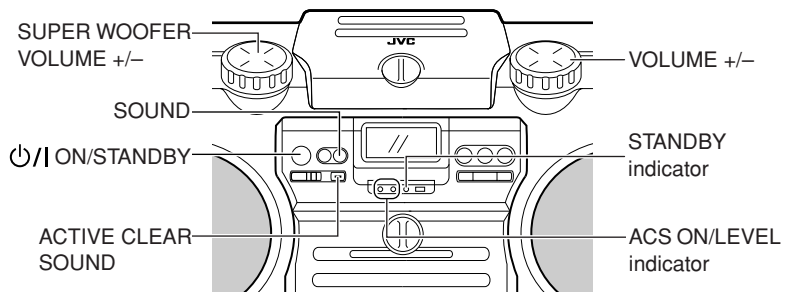
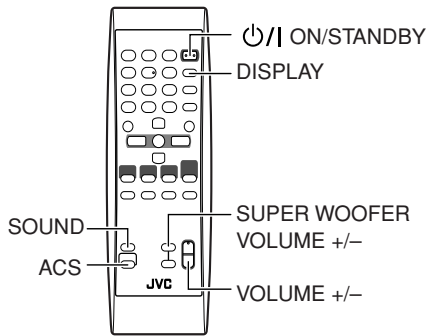

Turning the power on and off

Note: The lighting condition for the STANDBY indicator and the display differs depending on the power source.

Power source	STANDBY indicator/display
AC power	<ul style="list-style-type: none"> The STANDBY indicator lights when power is turned off. Backlighting of the display is illuminated when power is turned on.
Batteries or car battery (DC12V)*	<ul style="list-style-type: none"> The STANDBY indicator does not light. Backlighting of the display is not illuminated. With the system turned off (at standby), no indication is shown on the display.

* If no source is playing and no operation is done for about 4 minutes, "DC OFF" starts flashing on the display for about one minute before the system turns off automatically (except when the source is WIRELESS/FM/AM or AUX, or when the microphone (or guitar) is used).

Turning on the system

Press ON/STANDBY.

When the system is operated on batteries or car battery (DC12V), press ON/STANDBY on the system.

The STANDBY indicator goes out when the system is operated on AC power.

The display comes on and the system is ready to continue in the mode it was in when the power was last turned off.

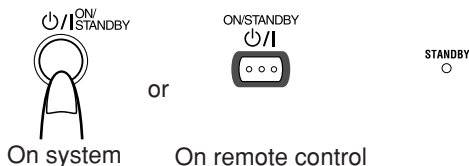

Turning off the system

Press ON/STANDBY again.

The STANDBY indicator lights up when the system is operated on AC power.

When the AC power is used, the CLOCK indicator and the time are displayed without backlighting.

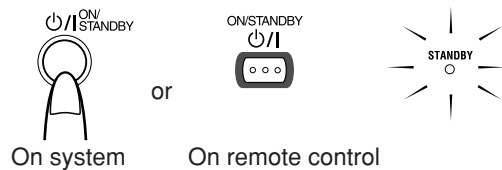

- Some power is always consumed even though power is turned off (called standby mode).
- To disconnect the system from mains (AC) supply completely, unplug the AC power cord from the AC outlet. When you unplug the AC power cord, the clock will be reset to "AM12:00" if no memory backup batteries are installed.

Adjusting the volume

You can adjust the volume level between 0 and 50.

Using the system

Turn the VOLUME +/- control clockwise to increase the volume or turn it counterclockwise to decrease the volume.

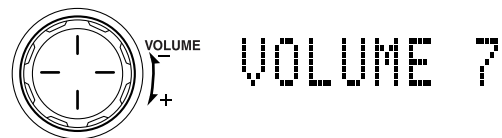

Using the remote control

Press VOLUME + to increase the volume or press VOLUME - to decrease it.

When you press and hold VOLUME + or -, the volume changes rapidly.

CAUTION: DO NOT start playing any source without first setting the volume to minimum, as a sudden blast of sound can damage your hearing, speakers and/or headphones.

For private listening

Connect a pair of headphones to the PHONES jack on the rear of the system (see page 6). No sound comes out of the speakers. Be sure to turn down the volume before connecting or putting on headphones.

Adjusting the super woofer volume

During play, you can adjust the bass level between BASS 1 (minimum) and BASS 6 (maximum).

Using the system

Turn the **SUPER WOOFER VOLUME +/-** control clockwise to increase the bass level or turn it counterclockwise to decrease the bass level.

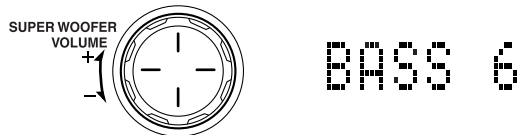

Using the remote control

Press **SUPER WOOFER VOLUME +** to increase the bass level or press **SUPER WOOFER VOLUME -** to decrease it.

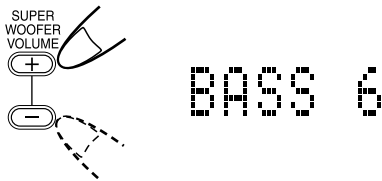

Note: This function is not effective when the headphones are in use.

Activating clear sound

The Active Clear Sound (ACS) circuit emphasizes high-frequency sound without lowering the signal-noise ratio, while adjusting its output according to the input signal level. This results in a better balance between the high-frequency sound and the low-frequency heavy bass.

Press **ACS (active clear sound)** on the system or on the remote control to turn it on or off.

When it is turned on, the ACS ON indicator lights in red.

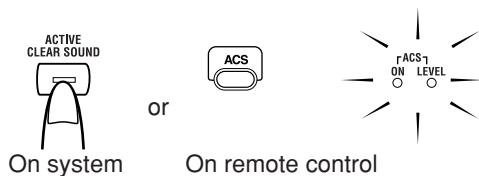

- The ACS LEVEL indicator flashes in green according to the input signal level.

Selecting the sound mode

Sound modes can be selected to enhance the type of music being played.

Press **SOUND** to select the sound mode.

Each time you press the button, the sound mode changes as follows:

FLAT → BEAT → POP → CLEAR

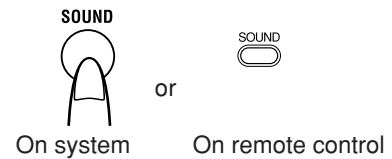

Sound mode selection:

BEAT: Set to this position for music with a heavy beat, such as rock and disco music.

POP: Set to this position for light music including popular and vocal music.

CLEAR: Set to this position for crisp and clear sounding music with transparent highs.

FLAT (no effect): Set to this position not to apply any sound mode.

Showing the time

While the power is turned on, you can see the current time (clock) at any time, as follows.

Using the remote control only

Press **DISPLAY**.

Each time you press the button, the display changes as follows:

FM 103.5 MHz ↔ AM 1200^{CLOCK}

Current sound source (e.g. FM103.5 MHz) → (clock) → (back to the beginning)

Note: To let the clock work, you need to set the clock first. (See "Setting the clock" on page 18.)

Listening to the radio

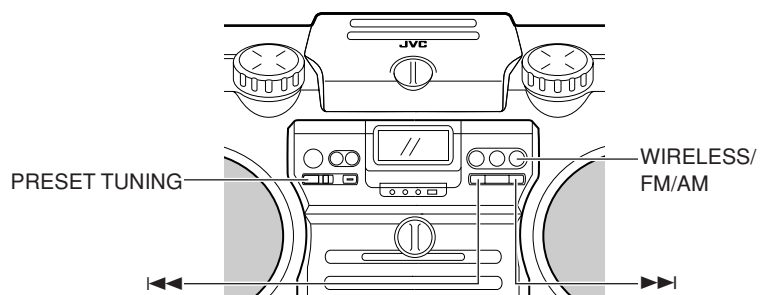
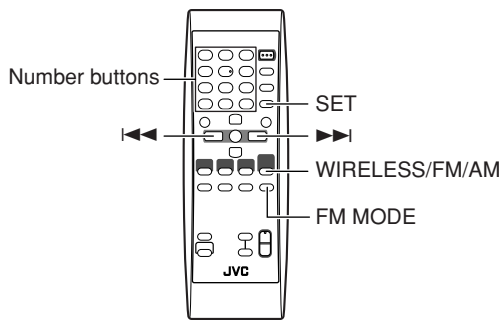

You can listen to FM and AM stations. Stations can be tuned in manually, automatically, or from preset memory storage.

■ Before listening to the radio, fully extend the FM telescopic antenna.

Tuning in to a station

1. Press WIRELESS/FM/AM repeatedly to select either FM or AM.

Each time you press WIRELESS/FM/AM, the band changes as follows:

WIRELESS → FM → AM → (back to the beginning)

- For “WIRELESS,” see page 17.

The system tunes in to the last tuned station. The following information appears on the display.

–When “Manual Tuning” or “Auto Tuning” was used to tune in to the last tuned station (see below), the band frequency appears.

FM 87.5 MHz

–When “Preset Tuning” was used to tune in to the last tuned station (see the right column), the preset number (displayed as “P-XX” on the display) and then the band frequency appear.

FM P-12 → FM 87.5 MHz
(After one second)

2. Select a station using one of the following methods.

- If an FM stereo broadcast is hard to receive or noisy, press FM MODE on the remote control. The MONO indicator lights up and the sound becomes monaural, but the reception improves. When you tune in to another station, the MONO indicator goes off and stereo effect restores automatically.

Note: AM broadcasts are monaural.

Manual Tuning

Press ◀◀ or ▶▶ repeatedly to move from frequency to frequency until you find the station you want.

OR

Auto Tuning

Press and hold ◀◀ or ▶▶ for one second or more.

The frequency changes automatically until a station frequency is found.

OR

■ Preset Tuning (possible only after presetting stations)

Select the desired preset number using PRESET TUNING on the system or the number buttons on the remote control. The preset number and then the band frequency appear on the display.

PRESET TUNING button: Each time you press the button, the preset number increases.

Number buttons: To select P-5, press 5.
To select P-15, press +10 then 5.
To select P-20, press +10 once then press 10.

Notice: To adjust the reception condition

For FM: Adjust the FM telescopic antenna’s length, angle and direction until the best reception is obtained.

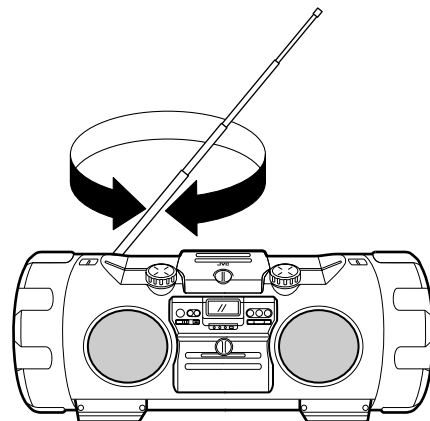

For AM: Change the direction of the system to obtain the best reception.

Placing the system near the window, for example, will improve AM reception.

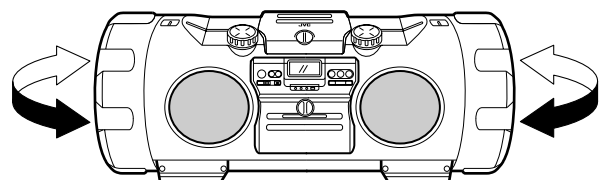

Presetting stations

You can preset up to 30 FM stations and 15 AM stations.

Note: Preset numbers may have been set to factory test frequencies prior to shipment. This is not a malfunction. You can preset the stations you want into memory as follows:

Using the remote control only

There is a time limit in doing the following steps. If the setting is canceled before you finish, start again from step 3.

1. Select a band (either AM or FM) by pressing WIRELESS/FM/AM repeatedly.
2. Press ◀◀ or ▶▶ to tune in to a station.
3. Press SET.

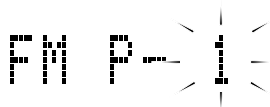

4. Press the number buttons to select the preset number you want.

5. Press SET.

“STORED” appears on the display and the station is stored.

6. Repeat above steps 1. to 5. for each station you want to store into memory with a preset number.

To change the preset stations, repeat the same steps as above to overwrite a new station.

CAUTION: To prevent the preset stations from being erased because of a power failure, etc., install memory backup batteries in the system. (See pages 5 and 6.)

Playing back discs

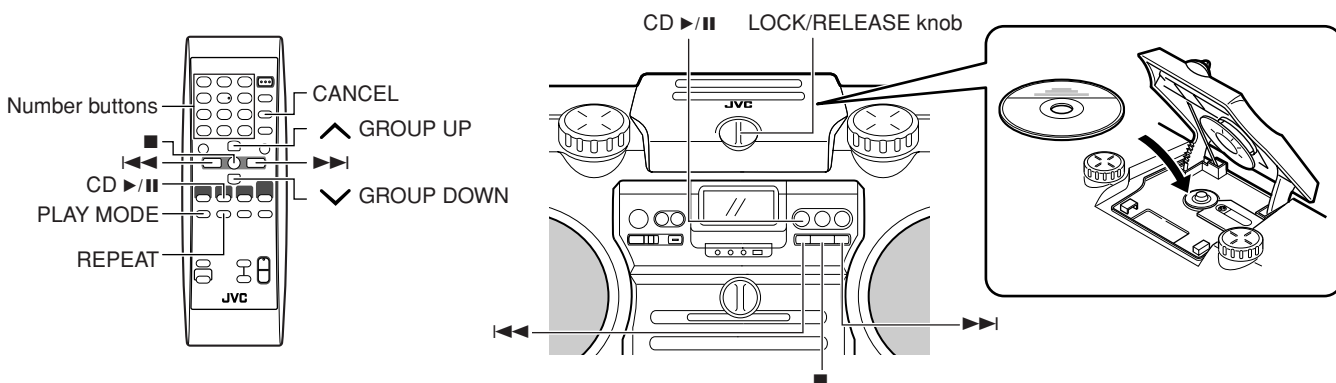

This system has been designed to play back the following discs—CD, finalized CD-R/CD-RW (recorded in audio CD format) and CD-R/CD-RW (in MP3 format).

- This system is not compatible with the other discs such as DVD, DVD-R, and DVD-RW.

Notes on MP3:

- The system can only recognize files (tracks) with “MP3” or “mp3” as the extensions, which can be in any combination of upper and lower case.
- It is recommended that you record your material at a 44.1 kHz sampling rate, using the 128 kbps data transfer rate.
- You can play back the discs containing the tracks in music CD format or MP3 files in ISO 9660 format.
- Some MP3 tracks or discs may not be played back because of their characteristics or recording conditions.
- MP3 discs require a longer readout time than normal discs.

- This system recognizes up to 999 tracks on a disc (or less depending on the recording condition of a disc).

Setting a disc

1. Turn the LOCK/RELEASE knob counterclockwise to open the disc compartment door.



2. Place a disc, with its label side up as shown above.

3. Close the disc compartment door and turn the knob to “LOCK” position.

To remove the disc, open the disc compartment door in stop mode.

- You can place an 8 cm (3-3/16”) disc without an adapter.
- If the disc cannot be read correctly (because it is scratched, for example), “NO PLAY” or “NO DISC” appears on the display.
- You can place a disc while listening to the other source.

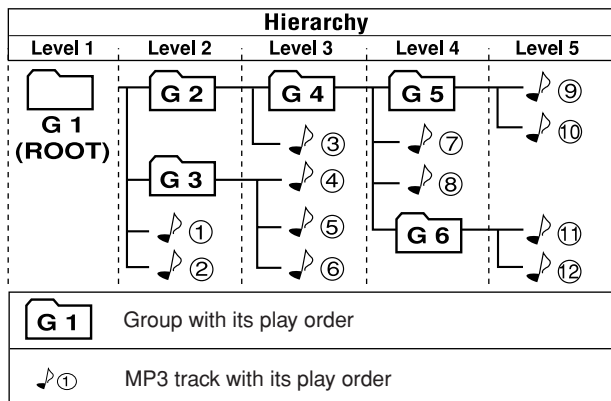

Using the disc player—Normal Play

To play a disc

1. Set a disc.

2. Press CD ►/II.

The first track of the disc starts playing.

For CDs:

Track number — 1 — Playback time — 005

For MP3 discs:

MP3 indicator — ● — MP3 — 27 — 009

- When playing an MP3 disc, the file name (then ID3 Tag if any) is displayed at the beginning of each track.
- If no disc is inserted, “NO DISC” appears on the display and the system remains in stop mode.
- The system automatically stops when the last track of the disc has finished playing.

To stop playing the disc, press ■.

The following information for the disc is displayed.

For CDs:

Total track number — 18 — Total playback time — 5045

For MP3 discs:

Total group number* — G30 — Total track number — T110
MP3 indicator — ● — MP3

* If a disc includes more than 99 groups, “G —” will appear on the display.

To pause, press CD ►/II. The playback time flashes on the display.

To cancel pause, press the same button again. Playback continues from the point where it was paused.

Note: Do not turn the LOCK/RELEASE knob during playback.

Skip Play

Press ◀◀ or ▶▶ to select the track you want to play during playback.

- Press ▶▶ once to skip to the beginning of the next track.
- Press ◀◀ to skip to the beginning of the track being played. Press ◀◀ twice quickly to skip to the beginning of the previous track.

You can also select a track in stop mode with the same buttons.

For CD: Selected track and its playback time are shown on the display.

For MP3: Group and track numbers (then ID3 Tag if any) are shown on the display.

To start playback, press CD ►/II.

Search Play

Press and hold ◀◀ or ▶▶ to fast forward/reverse the disc during playback.

You can quickly find a particular passage in the track you are listening to. During search play, you can hear the sound of approx. one fourth level.

To locate a track directly

Using the remote control only _____

Press the number buttons to directly play a track.

- To directly play track 5, press 5.
- To directly play track 15, press +10 then 5.
- To directly play track 20, press +10 once then press 10.

(Only for MP3 discs)

- To directly play track 109, press +100 once then press 9.
- To directly play track 125, press +100, +10, +10 then 5.

To select a group (for MP3 disc)

Using the remote control only _____

Press ^ GROUP UP or v GROUP DOWN to select the group you want to play during playing the MP3 disc.

- Press ^ GROUP UP to skip to the next group.
- Press v GROUP DOWN to skip to the previous group.

You can also select a group in stop mode with the same buttons.

To play the group after selection, press CD ►/II.

Programming the playing order of the tracks

Using the remote control only

- You can program up to 50 tracks in any desired order including the same tracks.
- You can only make a program when the system is stopped.
- While making a program, you cannot specify a group number to select a track.

1. Set a disc.

2. Press CD ►/II.

3. Press ■ to stop the disc.

4. Press PLAY MODE repeatedly to select "PROGRAM."

The system enters the programming mode and the PRGM indicator lights up.

5. Press the number buttons to select the track to program.

- For detailed operations, see "To locate a track directly" on page 11.

Example: For track 7, press 7.

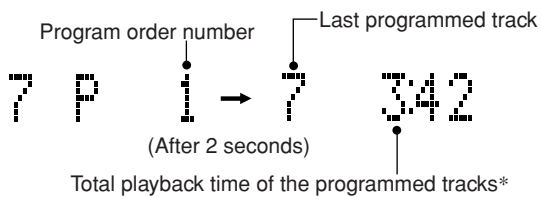

- * Total playback time will not appear while making a program using an MP3 disc.

6. Repeat step 5. to select other tracks for the program.

- To cancel the last track programmed, press CANCEL once.

7. Press CD ►/II.

The system plays the tracks in the order you have programmed them.

- You can skip to a particular program track by pressing ◀◀ or ▶▶ during program play.

While stopped:

- **To confirm the programmed tracks**, press ◀◀ or ▶▶ repeatedly; the tracks making up the program will successively be displayed in the programmed order.
 - To add a track to the end of the program, simply press the number buttons.
- **To delete the tracks in the program**, press CANCEL repeatedly. Each time you press the button, the last track will be erased.
- **To delete the entire program**, press and hold CANCEL until "CLEAR!" appears on the display.
 - Turning off the power will clear the program.
- **To exit from program mode**, press PLAY MODE repeatedly until the track number and total playback time appear on the display.

Each time you press the button, the play mode changes as follows:

Normal play → PROGRAM → RANDOM → (back to the beginning)

Note:

(For CDs) If the total playback time of the programmed tracks exceeds 99 minutes 59 seconds, "-- : --" will appear on the display.

Random play

The tracks will play in no special order when you use this mode.

Using the remote control only

1. Set a disc.

2. Press CD ►/II.

3. Press ■ to stop the disc.

4. Press PLAY MODE repeatedly to select "RANDOM."

The RANDOM indicator lights up on the display.

5. Press CD ►/II.

The tracks are played in random order once.

To skip a track during playback, press ▶▶ to skip to another track in the random sequence. The ◀◀ button works only to go back to the beginning of the current track.

While stopped:

- **To exit from random mode**, press PLAY MODE repeatedly until the track number and total playback time appear on the display.

Each time you press the button, the play mode changes as follows:

Normal play → PROGRAM → RANDOM → (back to the beginning)

Repeating tracks

You can repeat the tracks or individual track as many times as you like.

Using the remote control only

Press REPEAT.

Each time you press the button, repeat indicator changes as follows:

For CDs:

◀ ALL → ◀ → canceled → (back to the beginning)

- ◀ ALL: Repeats all the tracks on the disc.
- ◀ : Repeats the current track.

For MP3 discs:

◀ ALL → ◀ GROUP → ◀ → canceled → (back to the beginning)

- ◀ ALL: Repeats all the tracks on the disc.
- ◀ GROUP: In normal play mode, repeats all the tracks in a group.
In program and random play modes, group repeat cannot be selected.
- ◀ : Repeats the current track.

- Repeat mode (except "◀ GROUP") remains in effect even when you change the play mode.

To exit from repeat mode, press REPEAT until the repeat indicator on the display goes out.

Playing back tapes

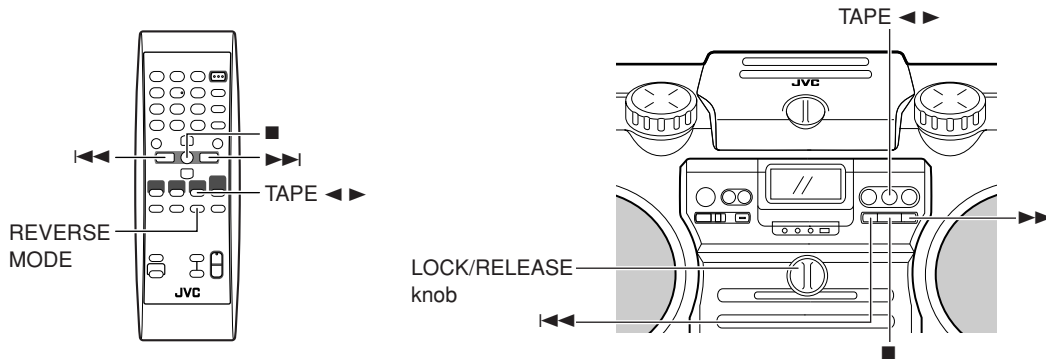

With automatic tape direction, you can listen to type I or II tapes without having to change any settings.

The use of tapes longer than 120 minutes is not recommended, since characteristic deterioration may occur and these tapes easily jam in the pinch-rollers and the capstans.

Regular play

1. Turn the **LOCK/RELEASE knob counterclockwise to open the cassette holder.**

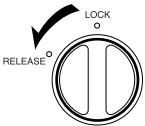

2. Put the cassette in, with the side you want to listen to facing you.

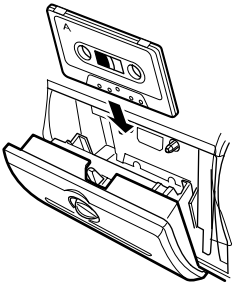

3. Close the holder gently and turn the knob to **“LOCK” position.**

4. Press **TAPE ◀ ▶.**

The tape is played in the direction shown by the tape direction indicator.

▶ **(Forward playback):** The side of the tape facing you is played back.

◀ **(Reverse playback):** The opposite side of the tape is played back.

5. If you need to change the playback direction, press **TAPE ◀ ▶.**

The opposite side tape direction indicator lights up and the tape playback direction changes.

To stop playing, press ■.

To remove the tape, stop the tape, and open the cassette holder by turning the LOCK/RELEASE knob to the “RELEASE” position.

Notes:

- Do not turn the LOCK/RELEASE knob during playback.
- When no tape is loaded in the deck, “NO TAPE” appears on the display.

To fast-wind/rewind a tape

Press ▶▶ or ◀◀ to fast-wind/rewind the tape.

- The cassette deck automatically stops when the tape reaches its end.

Reverse mode

You can set a tape to play just one side, both sides in succession, or both sides continuously.

Using the remote control only

Press **REVERSE MODE.**

Each time you press the button, reverse mode indicator changes as follows:

↔ → ↔ → (↺) → (back to the beginning)

- ↔: The cassette deck automatically stops after playing one side of the tape.
- ↺: The cassette deck automatically stops when playback in the reverse (◀) direction is finished.
- (↺): The cassette deck continues to play both sides of the tape until the ■ button is pressed.

Recording

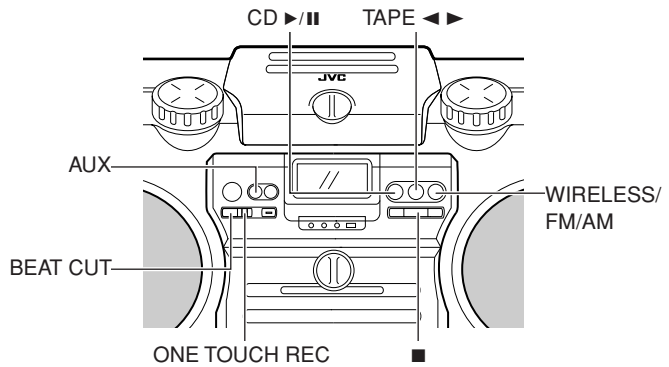
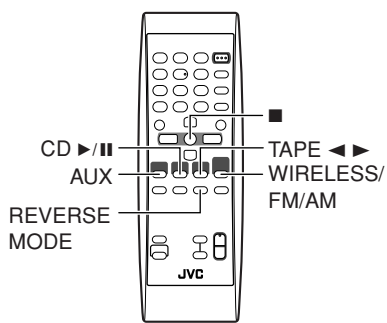

Things to know before you start recording

- It should be noted that it may be unlawful to re-record pre-recorded tapes, records, or discs without the consent of the owner of copyright in the sound or video recording, broadcast or cable programme and in any literary, dramatic, musical, or artistic work embodied therein.
- When you want to record onto both sides of a tape, you can set reverse mode to \rightleftarrows . Recording automatically stops after recording in the reverse (\blacktriangleleft) direction. Therefore, make sure that the tape direction is forward (\blacktriangleright) when recording with reverse mode is on.
- The recording level is automatically set correctly, so it is not affected by the VOLUME control on the system or by adjusting the sound effects. Thus, during recording you can adjust the sound you are actually listening to without affecting the recording level.
- Two small tabs on the back of the cassette tape, one for side A and one for side B, can be removed to prevent accidental erasure or recording.
- To record on a cassette with the tabs removed, you must cover the holes with adhesive tape first. However, when a type II tape is used, only cover part of the hole as shown, since the other part of the hole (type II detection slot) is used to detect the tape type.

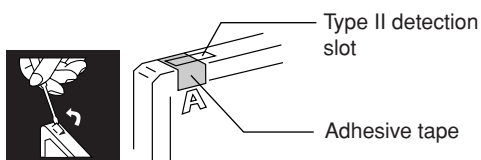

- Type I and type II tapes can be used for recording.

Note:

At the start and end of cassette tapes, there is leader tape which cannot be recorded onto. Thus, before recording, wind on the leader tape first to ensure getting the beginning of the recording.

CAUTION: If a recording you make has excessive noise or static, the system may have been too close to a TV which was on during the recording. Either turn off the TV or increase the distance between the TV and the system.

Standard recording

You can record any sound source to tape.

The sources are disc, tuner, auxiliary equipment, microphone, and guitar. The microphone sound and guitar sound can be mixed with any source.

1. Insert a blank or erasable cassette tape into the cassette deck.

Be sure that the tape direction indicator and the tape insertion direction are as follows:

[Forward and reverse recording]

Tape direction indicator	Tape insertion direction
\blacktriangleright (Forward)	 (Front view)
* Recording will be made on the tape side facing you.	
\blacktriangleleft (Reverse)	 (Front view)
* Recording will be made on the opposite side of the tape.	

- If the tape direction \blacktriangleleft (reverse) is lit, press TAPE $\blacktriangleleft\blacktriangleright$ to change the direction. (In this case, since the tape play starts, you need to press \blacksquare . Then, press \blacktriangleleft to rewind the tape up to the end point of the leader tape which cannot be recorded onto.)
- If the inserted tape is not fully rewound, press \blacktriangleleft to rewind the tape up to the end point of the leader tape which cannot be recorded onto.

2. If you want to record on both sides of the tape, press REVERSE MODE on the remote control to set the cassette deck in reverse mode.

Press the button until " \rightleftarrows " is lit.

3. Prepare the source, for example, tuning in to a radio station, or turning on the connected auxiliary equipment.

Note: For disc recording, refer to "Disc direct recording" described on page 15.

Continued on the next page...

4. Press ONE TOUCH REC on the system.

- The **REC** indicator lights up and the system starts recording.
- If the tab of the cassette tape is removed to protect erasure or recording, recording does not start.

Tips: When you want to record on both sides of the tape, start recording from the forward direction.

To stop at any time during the recording process, press ■.

Recording an AM station on a tape

When recording an AM broadcast, beats may be produced which are not heard when listening to the broadcast. If this happens, press BEAT CUT to eliminate the beats.

1. Set to AM station and start recording.

2. Press BEAT CUT to eliminate the beats.

Each time you press the button, the display changes as follows: B.CUT-1 → B.CUT-2 → B.CUT-3 → B.CUT-4 → (back to the beginning)

Disc direct recording

Everything on the disc goes onto the tape in the order it is on the disc, or according to the order you have set in a program.

1. Insert a blank or erasable cassette tape into the cassette deck.

Be sure that the tape direction indicator and the tape insertion direction are as follows:

[Forward recording]

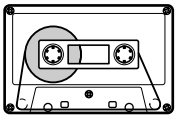
Tape direction indicator	Tape insertion direction
▶ (Forward)	 (Front view)
* Recording will be made on the tape side facing you.	

2. If you want to record on both sides of the tape, press REVERSE MODE on the remote control to set the system in reverse mode.

Press the button until “↔” is lit.

3. Set a disc.

4. Press CD ▶/II.

5. Press ■.

- If you want to record specific tracks only, program the tracks first. You can check their total playback time on the display during programming. (See page 12.)

6. Choose whether to have pauses between tracks.

- If nothing is done, a non-recorded pause of about four seconds will be automatically made between tracks.
- If you do not want pauses between tracks, press CD ▶/II twice to enter pause mode—only possible with CDs.

7. Press ONE TOUCH REC on the system.

The **REC** indicator lights up and the cassette deck starts recording.

- When the tape reaches its end at the middle of a song in the forward direction (▶), the recording in the reverse direction (◀) will start from the beginning of that track (or previous track). See diagram below.

Ex.: Case 1

[Recording direction ▶ (forward)]

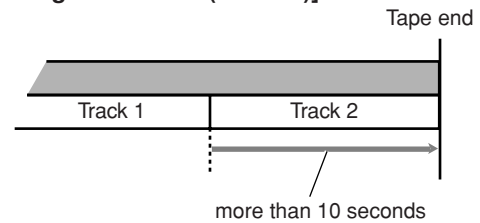

- * The recording in reverse side (◀) starts from the beginning of track 2.

Ex.: Case 2

[Recording direction ▶ (forward)]

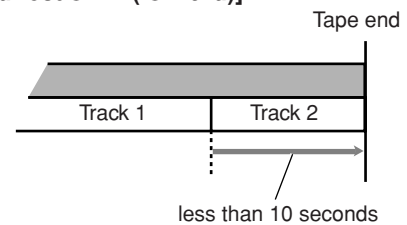

- * The recording in reverse side (◀) starts from the beginning of track 1.

- After the disc player has played the entire disc, or all the programmed tracks, the tape automatically stops.
- Recording will also stop when the end of the reverse side (◀) is reached (even if the disc play is not yet over).

To stop at any time during the recording process, press ■.

The tape stops after four seconds.

Note:

When making SLEEP timer settings while performing disc direct recording, set enough time to allow the disc to finish playing; otherwise, the power will go off before recording is completed.

One Track Recording

You can record the current track being played.

1. Insert a blank or erasable cassette tape into the cassette deck.

2. Play the track you wish to record.

3. Press ONE TOUCH REC on the system.

The disc player returns to the beginning of that track and the track is recorded on the tape. After recording, the disc player and the cassette deck automatically stop.

Listening to auxiliary equipment

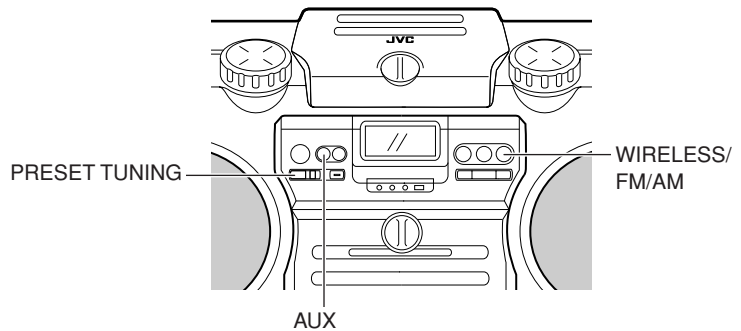
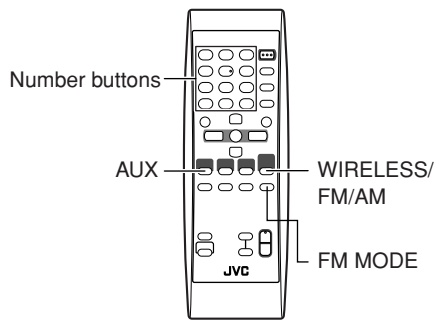

You can listen to auxiliary equipment with the following methods:

- Transmitting sound on FM wave
- Connecting to the AUX IN jack

Note: For operation of the auxiliary equipment, refer to its instructions.

■ Transmitting sound on FM wave

You can connect auxiliary equipment such as a digital audio player to the wireless transmitter, then transmit the sound signals on FM wave.

■ Installing the batteries to the wireless transmitter

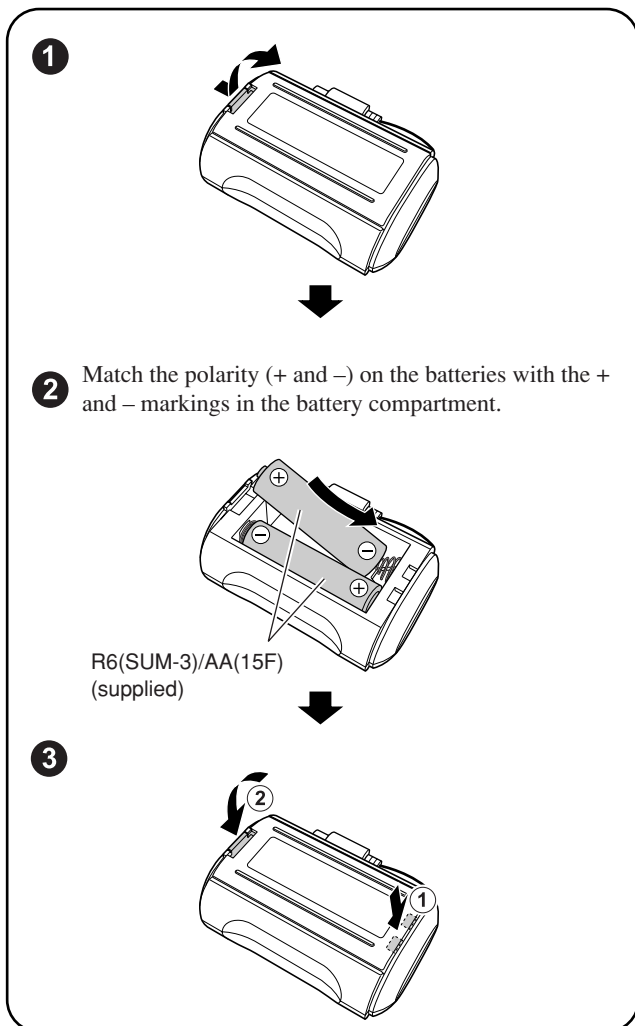

Listening to auxiliary equipment

1. Connect the wireless transmitter to the headphones jack of auxiliary equipment.

2. Select one of the position numbers on the wireless transmitter.

- To check the assigned frequency to each the position number, refer to the label put on the rear of the wireless transmitter.
- Make sure that no local FM station in you area uses the same frequency.

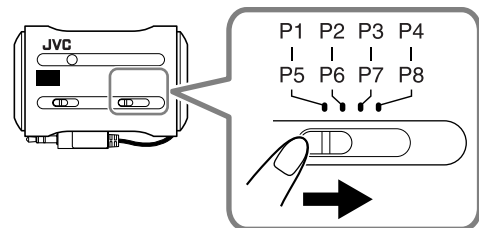

3. Turn on the wireless transmitter.

The red lamp lights up.

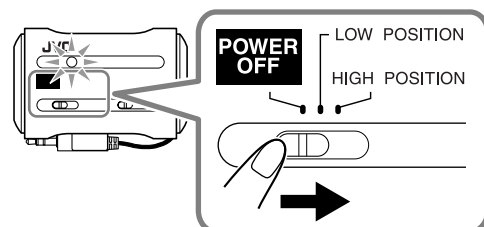

- To select a position number from P1 - P4, set the switch to LOW POSITION.
- To select a position number from P5 - P8, set the switch to HIGH POSITION.

4. Set the volume level of the system to minimum.

Continued on the next page...

5. Press WIRELESS/FM/AM to select WIRELESS as the source.

The system tunes in to the last tuned frequency. The following information appears on the display.

POSITN 1 → WIRELESS

(After one second)

6. Select the same position number as you have selected on the wireless transmitter in step 2, on page 16.

- **On the remote control:** Press the number button corresponding to the position number.
- **On the system:** Press PRESET TUNING repeatedly to select the position number.

7. Start playing the connected equipment, then adjust the volume on the equipment.

8. Adjust the volume of the system to the desired listening level.

- **If received sounds are noisy,** press FM MODE on the remote control. The MONO indicator lights up and the sound becomes monaural, but the reception improves. When you tune in to another frequency using ◀◀ or ▶▶, the MONO indicator goes off and stereo effect restores automatically.

Notice: • To adjust the reception condition

Adjust the FM telescopic antenna's length, angle and direction until the best reception is obtained (see page 9).

• To avoid sound distortion

Make sure not to increase the volume of the connected equipment too high.

Notes:

- If the frequency (position number) you select to receive the signals from the wireless transmitter is used by an FM station or is adjacent to an FM station frequency, it interferes with the reception from the wireless transmitter. If this happens, select another frequency (position number).
- If you are nearby the TV or FM stations which transmit strong signals, it interferes with the reception from the wireless transmitter. In this case, you may not be able to use the wireless transmitter.
- To get good reception from the wireless transmitter:
 - Make sure that there is no obstruction between the system and the wireless transmitter.
 - Straighten the connecting cord of the wireless transmitter as much as possible.

Presetting frequencies

You can preset up to eight frequencies.

Using the remote control only

There is a time limit in doing the following steps. If the setting is canceled before you finish, start again from step 3.

1. Select WIRELESS by pressing WIRELESS/FM/AM.

2. Press ◀◀ or ▶▶ to tune in to a frequency.

3. Press SET.

POSITN 1

4. Press the number buttons (1 – 8) to select the preset number you want.

5. Press SET.

“STORED” appears on the display and the frequency is stored.

6. Repeat above steps 1, to 5, for each frequency you want to store into memory with a preset number.

To change the preset frequencies, repeat the same steps as above to overwrite a new frequency.

Note:

When you listen to an auxiliary equipment connected to the wireless transmitter after changing the preset frequency initially memorized in the system, set the frequency back to the initial one according to the above procedure; otherwise, you cannot receive the signal even though you select the same position number as the one on the transmitter.

Following table shows the initial settings of the position numbers on the system.

Initial settings of the position numbers:

Position no.	Frequency	Position no.	Frequency
POSITN 1	88.10 MHz	POSITN 5	107.10 MHz
POSITN 2	88.30 MHz	POSITN 6	107.30 MHz
POSITN 3	88.50 MHz	POSITN 7	107.50 MHz
POSITN 4	88.70 MHz	POSITN 8	107.70 MHz

CAUTION: To prevent the preset frequencies from being erased because of a power failure, etc., install memory backup batteries in the system. (See pages 5 and 6.)

■ Connecting to the AUX IN jack

First make sure that the auxiliary equipment is properly connected to the system. (See pages 5 and 6.)

1. Set the volume level to minimum.

2. Press AUX.

“AUX” appears on the display.

AUX

- To listen to the auxiliary equipment, start playing the auxiliary equipment.

3. Adjust the volume to the desired listening level.

4. Apply sound effects, if you wish.

- Adjust the super woofer volume to reinforce the bass sound.

Using the microphone/guitar

Microphone/guitar mixing

Using a microphone or a guitar (not supplied), you can mix its sound with a source sound.

- 1. Make sure the MIC/GUITAR LEVEL control on the rear of the system is properly set.**
 - When using a microphone, make sure the knob is pressed in (■).
 - When using a guitar, make sure the knob is released (□).
- 2. Set the MIC/GUITAR LEVEL control to MIN by turning it fully counterclockwise.**
- 3. Connect a microphone or a guitar into the MIC/GUITAR INPUT jack on the rear of the system.**
- 4. Start a source: disc, tape, tuner, or other equipment.**

- 5. Adjust the VOLUME +/- control and the MIC/GUITAR LEVEL control, as you play the microphone or the guitar.**

CAUTION: DO NOT connect a bass guitar to the MIC/GUITAR INPUT jack, as it may damage the system.

Recording microphone or guitar mixing on a tape

- 1. Follow the above steps 1. - 5.**
- 2. To record, follow the steps in “Standard recording.” (See page 14.)**

Note: If “howling” occurs when using the microphone, keep the microphone away from the speaker.

Using the timer

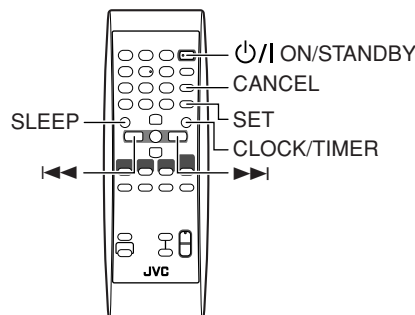

The timers let you control the listening and recording functions automatically.

Setting the clock

When the power is first supplied, the CLOCK indicator and “AM12:00” flash on the display. Set the clock.

Note:

The clock must be correctly set for the timers to work.

Using the remote control only

- 1. Press ON/STANDBY .**
- 2. Press CLOCK/TIMER repeatedly until the CLOCK indicator lights up.**

The hour digit flashes on the display.
- 3. Press right arrow or left arrow to select the hour.**
 - When you press and hold the button, the hour digit changes continuously.

- 4. Press SET to set the hour.**

The minutes digits start flashing on the display.

- 5. Press right arrow or left arrow to select the minute.**
 - When you press and hold the button, the minute digit changes continuously.
 - If you want to change the hour setting, press CANCEL.

- 6. Press SET to finish setting the clock.**

CAUTION: If memory backup batteries are exhausted or not installed, and the AC power cord is plugged in again after being disconnected, or power is restored after a power failure, the CLOCK indicator will flash on the display. Set the current time (clock) again.

Setting the sleep timer

Use the sleep timer to turn the system off after a certain number of minutes when it is playing. By setting the sleep timer, you can fall asleep to the music and know that your system will turn off by itself rather than playing all night.

- You can set the sleep timer only when the system is turned on.

Using the remote control only

1. Press SLEEP.

The SLEEP indicator lights up on the display.

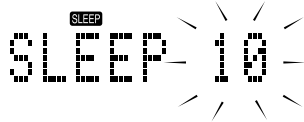

2. Set the length of time you want the source to play before shutting off.

Each time you press the button, it changes the number of minutes shown on the display in this sequence:

10 → 20 → 30 → 60 → 90 → 120 → OFF → (back to the beginning)

After setting the number of minutes for the sleep timer, the indication will stop flashing and go off.

The system is now set to turn off after the number of minutes you set.

To confirm the sleep time:

When SLEEP is pressed, the remaining sleep time is displayed. Wait until the display returns to the original display.

To cancel the sleep timer:

Press SLEEP repeatedly to select "OFF." Turning off the system also cancels the sleep timer.

Setting the daily timer

Once the timer has been set, it will be activated at the same time everyday until the timer is turned off. Recording timer works only one time.

- While the timer is being set, the timer indicator (⏰) lights up.
- While the timer has been set, the timer indicator (⏰) also lights up if the power is supplied through the AC outlet.
- While the timer is working, the timer indicator (⏰) flashes.

Using the remote control only

1. Press ⏻/| ON/STANDBY.

2. Press CLOCK/TIMER.

"TIMER ON?" appears.

- Press SET to activate the timer setting you have made before.
- Press CANCEL to cancel the timer.
- Go to the next step to set the timer first time (or reset the timer).

3. Press CLOCK/TIMER again, so that the timer indicator (⏰) and ON indicator light up.

The hour digit of the current ON time flashes on the display.

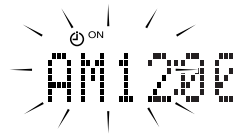

4. Set the on-time you want the system to turn on.

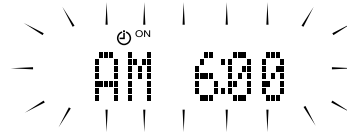

- (1) Press ►► or ◄◄ to select the hour, then press SET.
- (2) Press ►► or ◄◄ to select the minute, then press SET. The OFF indicator lights up.
 - Press and hold the button to change the time rapidly.
 - If you want to change the time setting, press CANCEL.

5. Set the OFF time (example: PM1:30).

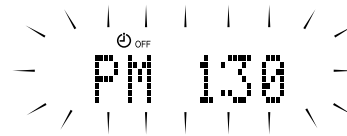

- (1) Press ►► or ◄◄ to select the hour, then press SET.
- (2) Press ►► or ◄◄ to select the minute, then press SET.
 - Press and hold the button to change the time rapidly.
 - If you want to change the time setting, press CANCEL.

6. Press ►► or ◄◄ to select the music source you want to listen to, then press SET.

Each time you press the button, the display changes as shown below:

TUNER → TU → TAPE → CD → TAPE → (back to the beginning)

When you select the "TU → TAPE";

- The REC indicator appears on the display.
- The timer will be canceled after tuner recording has been finished.

7. Press ►► or ◄◄ to select the volume level, then press SET.

--: The current volume level will be used.

0 to 50: When the timer is turned on, the volume will be automatically set to the selected level.



- The current timer setting appears for confirmation.

8. Before turning off the system, prepare the music source selected in step 6, on page 19.

TUNER: Tune in to the desired frequency (FM/AM/WIRELESS).

TU→TAPE: Tune in to the frequency (FM/AM/WIRELESS) you want to record. Insert a cassette tape for recording.

CD: Set a disc.

TAPE: Insert a tape.

Notes:

- By using "WIRELESS," you can also record the sounds through the auxiliary equipment connected to the wireless transmitter.
- Listening to or recording auxiliary equipment connected to the wireless transmitter, start playing the equipment before the timer turns on.

9. Press ON/STANDBY to turn off the system.

- When the timer turns on, the volume level gradually increases from 0 (zero) to the preset level in step 7, on page 19. However, if the volume has been set to "--", the volume level will be set to the last level directly.

To cancel the operation, press CLOCK/TIMER until the display returns to the original one.

To cancel the timer, press CLOCK/TIMER once, then press CANCEL. ("TIMEROFF" appears, only when power is on.)

To reactivate (or confirm) the canceled timer, press CLOCK/TIMER once, then press SET. (The current timer setting appears for confirmation.)

Notes:

- The timer cannot be set if on-time and off-time are the same.
- The timer does not work if the system is not in the standby mode (the system needs to be in standby mode at least one minute before the on-time).

CAUTION: If memory backup batteries are exhausted or not installed, and the AC power cord is disconnected or there is a power failure, time settings will be erased from memory. If this happens, set the current time (clock) and perform the timer setting again.

Care and maintenance

Handle your discs carefully, and they will last a long time.

Compact discs



- This system can play back the following discs:
 - Audio CD
 - Finalized CD-R/CD-RW recorded in audio CD format or MP3 format

However, continued use of irregular shape discs (heart-shape, octagonal, etc.) can damage the system.

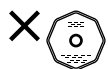
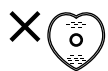

- Remove the disc from its case by holding it at the edges while pressing the case's center hole lightly.
- Do not touch the shiny surface of the disc, or bend the disc.

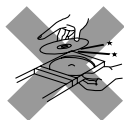

- Put the disc back in its case after use to prevent warping.
- Be careful not to scratch the surface of the disc when placing it back in the case.
- Avoid exposure to direct sunlight, temperature extremes, and moisture.



- A dirty disc may not play correctly. If a disc does become dirty, wipe it with a soft cloth in a straight line from center to edge.

CAUTION: Do not use any solvent (for example, conventional record cleaner, spray thinner, benzene, etc.) to clean a disc.

General notes

In general, you will have the best performance by keeping your discs and the mechanism clean.

- Store discs in their cases, and keep them in cabinets or on shelves.
- Keep the disc compartment door closed when not in use.

Cleaning the lens

If the lens in the pickup is dirty, dropout, etc., could degrade sound. Open the disc compartment door and clean the lens as shown.

- Use a blower (available at camera stores) to blow dust off the lens.

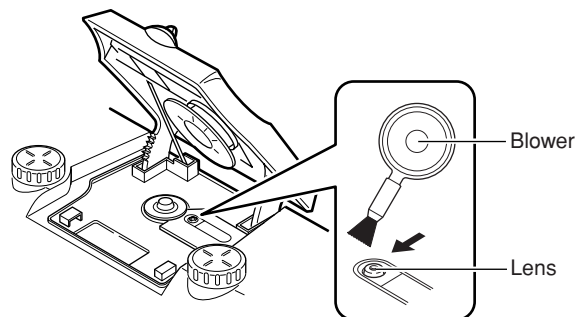

- If there are fingerprints, etc. on the lens, gently wipe clean with a cotton swab.

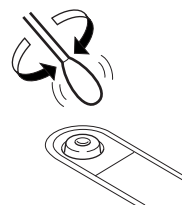

Continued on the next page...

Moisture condensation



Moisture may condense on the lens inside the system in the following cases:

- After turning on heating in the room.
- In a damp room.
- If the system is brought directly from a cold to a warm place.

Should this occur, the system may malfunction. In this case, leave the system turned on for a few hours until the moisture evaporates, unplug the AC power cord, and then plug it in again.

Cassette tapes



- If the tape is loose, it may get stretched, cut, or caught in the cassette. Take up the slack by inserting a pencil in one of the reels and rotating.



- Do not touch the tape surface.



- Do not store the tape:
 - In dusty places
 - In direct sunlight or heat
 - In moist areas
 - On a TV or speaker
 - Near a magnet

Cassette deck

- If the heads, capstans, or pinch-rollers of the cassette deck become dirty, the following may occur:
 - Loss of sound quality
 - Discontinuous sound
 - Fading
 - Incomplete erasure
 - Difficulty recording
- Clean the heads, capstans, and pinch-rollers using a cotton swab moistened with alcohol.

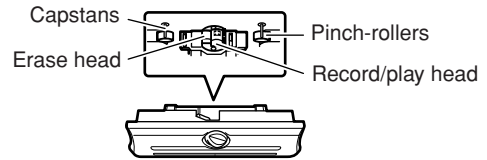

- If the heads become magnetized, the system will produce noise or lose high frequency notes.
- To demagnetize the heads, turn off the system, and use a head demagnetizer (available at electronics and record shops).

Troubleshooting

- If you are having a problem with your system, check this list for a possible solution before calling for service.
- If you cannot solve the problem from the hints given here, or the system has been physically damaged, call a qualified person, such as your dealer, for service.

Symptom	Possible cause	Action
Power does not come on.	The power cord is not connected to an AC outlet.	Insert the plug into the socket.
No sound is heard.	<ul style="list-style-type: none"> • Connections are incorrect, or loose. • Headphones are connected. • MP3 disc is recorded with “packet writing.” 	<ul style="list-style-type: none"> • Check all connections and make corrections. (See pages 5 and 6.) • Disconnect the headphones. • It cannot be played. Replace the disc.
Poor FM reception.	The FM telescopic antenna is not properly extended and positioned.	Fully extend the FM telescopic antenna and turn it for the best reception.
The track skips.	The disc is dirty or scratched.	Clean or replace the disc.
The disc does not play (“NO PLAY” or “NO DISC” appears).	<ul style="list-style-type: none"> • The disc is upside down. • The disc is dirty or scratched. 	<ul style="list-style-type: none"> • Put the disc in with the label side up. • Change the disc.
Specific files (tracks) on an MP3 disc are not played.	Files other than MP3 are included in the disc.	They cannot be played.
Hard to hear auxiliary equipment connected to the wireless transmitter because of noise.	<ul style="list-style-type: none"> • The selected position number on the system is different from the one selected on the wireless transmitter. • The volume of the connected equipment is low. • The wireless transmitter is far from the system. 	<ul style="list-style-type: none"> • Select the same position number as you have selected on the wireless transmitter. (See page 17.) • Turn up the volume.
Unable to record.	Cassette record protect tabs are removed.	Cover the holes on the back edge of the cassette with tape.

Symptom	Possible cause	Action
Unable to operate the remote control.	<ul style="list-style-type: none"> The path between the remote control and the sensor on the system is blocked. The batteries have lost their charge. 	<ul style="list-style-type: none"> Remove the obstruction. Replace the batteries.
Operations are disabled.	The built-in microprocessor has malfunctioned due to external electrical interference.	Unplug the system then plug it back in after a few minutes.
The cassette holder cannot be opened.	During tape play, the power cord has been unplugged.	Plug in the power cord and press the ⏻/I ON/STANDBY button.
Indicators and the display do not light up while in standby mode.	Batteries or DC power is used to supply the power.	

Specifications

Amplifier

Output Power

6 W per channel, min. RMS, at 4 Ω from 150 Hz to 15 kHz with no more than 10% total harmonic distortion.
20 W per channel woofer, min. RMS into 4 Ω at 60 Hz with no more than 10% total harmonic distortion.

Input Sensitivity/Impedance (1 kHz)

AUX IN 300 mV/47 kΩ

MIC/GUITAR INPUT: Switchable

MIC 200 Ω – 2 kΩ (6.3 mm dia. plug)

GUITAR 100 kΩ – 1 MΩ (6.3 mm dia. plug)

Output Sensitivity/Impedance (1 kHz)

Phones 16 Ω – 1 kΩ

0 – 12 mW/ch output into 32 Ω

Cassette Deck

Frequency Response

Type II (High position) 60 Hz – 14 kHz

Wow and Flutter 0.15% (WRMS)

Disc Player

Dynamic range 90 dB

Signal-to-noise ratio 95 dB

Wow and Flutter Unmeasurable

Tuner

WIRELESS

Tuning Range 87.50 MHz – 108.00 MHz

FM Tuner

Tuning Range 87.5 MHz – 108.0 MHz

AM Tuner

Tuning Range 530 kHz – 1 710 kHz

Antenna

FM telescopic antenna

Ferrite core antenna for AM

Speakers

Full range 8 cm (3-3/16") × 2, 4 Ω

Super woofer 16 cm (6-5/16") × 2, 4 Ω

Wireless Transmitter (VFT-001)

Power Requirements DC 3 V ("R6/AA(15F)" batteries [2])

Transmitting Frequencies

88.10 MHz, 88.30 MHz, 88.50 MHz,
88.70 MHz, 107.10 MHz, 107.30 MHz,
107.50 MHz, 107.70 MHz

Input terminal Stereo mini plug

Frequency response 50 Hz to 12 000 Hz

Battery life (at normal temperature)

Approx. 50 hours (with Alkaline batteries)

Approx. 20 hours (with Manganese batteries)

Dimensions 78 mm × 55 mm × 35 mm (W/H/D)

(3-1/8" × 2-3/16" × 1-7/16")

Mass

Approx. 50 g (0.12 lbs) (without batteries)

General

Dimensions 690 mm × 239 mm × 296 mm (W/H/D)

(27-3/16" × 9-7/16" × 11-11/16")

Mass

9.5 kg (21 lbs) (without batteries)

10.6 kg (23.4 lbs) (with batteries)

Power Specifications

Power Requirements AC 120 V ~ , 60 Hz

DC 15 V ("R20/D(13F)" batteries [10])

External DC 12 V (car battery via optional

CA-R120 car adapter)

Power Consumption 50 W (power on mode)

1.6 W (in standby mode)

Design and specifications are subject to change without notice.

For U.S.A.

TO OUR VALUED CUSTOMER ———

THANK YOU FOR PURCHASING THIS JVC PRODUCT.
WE WANT TO HELP YOU ACHIEVE A PERFECT EXPERIENCE.

**NEED HELP ON HOW TO HOOK UP?
NEED ASSISTANCE ON HOW TO OPERATE?
NEED TO LOCATE A JVC SERVICE CENTER?
LIKE TO PURCHASE ACCESSORIES?**

JVC[®] IS HERE TO HELP!
TOLL FREE: 1(800)252-5722
<http://www.jvc.com>

Remember to retain your Bill of Sale for Warranty Service.

————— **Do not attempt to service the product yourself** —————

Caution

To prevent electrical shock, do not open the cabinet.
There are no user serviceable parts inside.
Please refer to qualified service personnel for repairs.

For U.S.A.



LIMITED WARRANTY

AUDIO-1 **USA ONLY**

ONLY FOR PRODUCT PURCHASED IN U.S.A.

JVC COMPANY OF AMERICA (JVC) warrants this product and all parts thereof, except as set forth below ONLY TO THE ORIGINAL RETAIL PURCHASER to be FREE FROM DEFECTIVE MATERIALS AND WORKMANSHIP from the date of original purchase for the period shown below. ("The Warranty Period")

PARTS	1 YR	LABOR	1 YR
-------	-------------	-------	-------------

THIS LIMITED WARRANTY IS VALID ONLY IN THE FIFTY (50) UNITED STATES, THE DISTRICT OF COLUMBIA AND IN THE COMMONWEALTH OF PUERTO RICO.

WHAT WE WILL DO:

If this product is found to be defective within the warranty period, JVC will repair or replace defective parts with new or rebuilt equivalents at no charge to the original owner. Such repair and replacement services shall be rendered by JVC during normal business hours at JVC authorized service centers. Parts used for replacement are warranted only for the remainder of the Warranty Period. All products may be brought to a JVC authorized service center on a carry-in basis. Color televisions with a screen size of 27" or greater qualify for in-home service. In such cases, a technician will come to your home and either repair the TV there or remove and return it if it cannot be repaired in your home.

WHAT YOU MUST DO FOR WARRANTY SERVICE:

Please do not return your product to the retailer
Instead, return your product to the JVC authorized service center nearest you. If shipping the product to the service center, please be sure to package it carefully, preferably in the original packaging, and include a brief description of the problem(s). Please call 1-800-252-5722 to locate the nearest JVC authorized service center. Service locations can also be obtained from our website <http://www.jvc.com>. If your product qualifies for in-home service, the service representative will require clear access to the product.

If you have any questions concerning your JVC Product, please contact our Customer Relations Department at 800-252-5722

WHAT IS NOT COVERED:

- This limited warranty provided by JVC does not cover:
1. Products which have been subject to abuse, accident, alteration, modification, tampering, negligence, misuse, faulty installation, lack of reasonable care, or if repaired or serviced by anyone other than a service facility authorized by JVC to render such service, or if affixed to any attachment not provided with the products, or if the model or serial number has been altered, tampered with, defaced or removed;
 2. Initial installation, installation and removal from cabinets or mounting systems.
 3. Operational adjustments covered in the Owner's Manual, normal maintenance, video and audio head cleaning;
 4. Damage that occurs in shipment, due to act of God, and cosmetic damage;
 5. Signal reception problems and failures due to line power surge;
 6. Video Pick-up Tubes/CCD Image Sensors are covered for 90 days from the date of purchase;
 7. Accessories;
 8. Batteries (except that Rechargeable Batteries are covered for 90 days from the date of purchase);
 9. Products used for commercial purposes, including, but not limited to rental.

There are no express warranties except as listed above.

THE DURATION OF ANY IMPLIED WARRANTIES, INCLUDING THE IMPLIED WARRANTY OF MERCHANTABILITY, IS LIMITED TO THE DURATION OF THE EXPRESS WARRANTY HEREIN.

JVC SHALL NOT BE LIABLE FOR ANY LOSS OF USE OF THE PRODUCT, INCONVIENCE, OR ANY OTHER DAMAGES, WHETHER DIRECT, INCIDENTAL OR CONSEQUENTIAL (INCLUDING, WITHOUT LIMITATION, DAMAGE TO TAPES, RECORDS OR DISCS) RESULTING FROM THE USE OF THIS PRODUCT, OR ARISING OUT OF ANY BREACH OF THIS WARRANTY. ALL EXPRESS AND IMPLIED WARRANTIES, INCLUDING THE WARRANTIES OF MERCHANTABILITY AND FITNESS FOR PARTICULAR PURPOSE, ARE LIMITED TO THE WARRANTY PERIOD SET FORTH ABOVE.

Some states do not allow the exclusion of incidental or consequential damages or limitations on how long an implied warranty lasts, so these limitations or exclusions may not apply to you. This warranty gives you specific legal rights and you may also have other rights which vary from state to state.

JVC COMPANY OF AMERICA 1700 Valley Road
 DIVISION OF JVC AMERICAS CORP. Wayne, NJ 07470
<http://www.jvc.com>

REFURBISHED PRODUCTS CARRY A SEPARATE WARRANTY, THIS WARRANTY DOES NOT APPLY. FOR DETAIL OF REFURBISHED PRODUCT WARRANTY, PLEASE REFER TO THE REFURBISHED PRODUCT WARRANTY INFORMATION PACKAGED WITH EACH REFURBISHED PRODUCT.

For customer use:

Enter below the Model No. and Serial No. which is located either on the rear, bottom or side of the cabinet. Retain this information for future reference.

Model No. : _____ Serial No. : _____
 Purchase date : _____ Name of dealer : _____

RV-NB10B/RV-NB10W

POWERED WOOFER CD SYSTEM

JVC