

ARSENAL

SUBWOOFER

CAISSON DE GRAVE

CS-AW8520

CS-AW8540

ENGLISH

FRANÇAIS

ESPAÑOL



CS-AW8520 & CS-AW8540

JVC

INSTRUCTION MANUAL
MANUEL D'INSTRUCTIONS
MANUAL DE INSTRUCCIONES

For Customer Use:
Enter below the Model No, and Serial No, which is located either on the rear or bottom of the speaker unit. Retain this information for future reference.

Model No. _____
Serial No. _____

LVT1861-001A

Thank you for purchasing the ARSENAL Car Stereo Speaker. These Speakers can be mounted in the trunk of your vehicle. For the secure installation and perfect operation of your speakers, please read the following carefully.

Parts

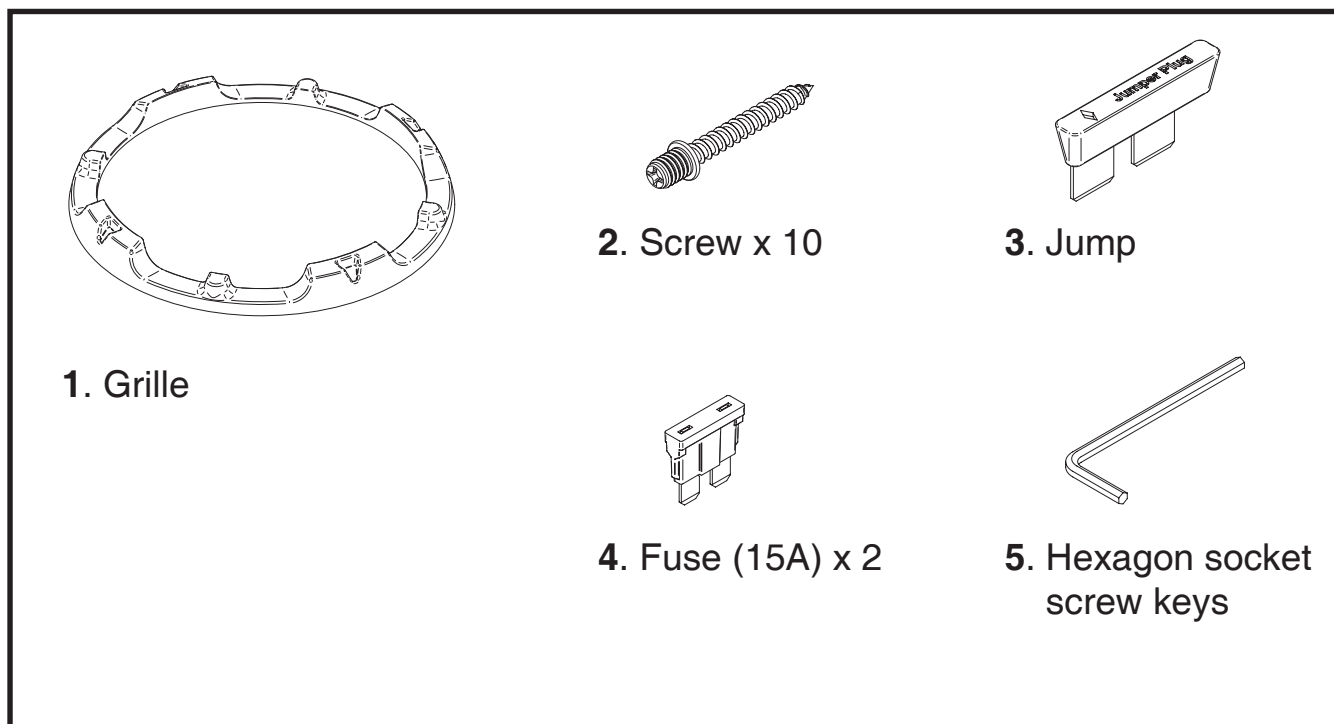

For proper installation and use

1. Before connecting the speakers to the amplifier, confirm that the power has been turned off. The click noise generated by the connection if the power is on may damage the speakers.
2. The amplifier and speakers should be connected between corresponding terminals, i.e. left to left, and right to right, as well as "+" to "+", and "-" to "-". Connection with reversed polarity will degrade the quality of stereo reproduction.
3. Do not subject the speakers to excessive input. The power handling capacity of the CS-AW8520/CS-AW8540 is 1500 watts (R.M.S. MUSIC POWER). Any excessive input may damage the speakers.
4. The CS-AW8520/CS-AW8540 has an impedance of 2Ω, 4Ω, 8Ω. Make sure that the output impedance of the amplifier's speaker terminal is rated at 2Ω, 4Ω, 8Ω.
5. When cleaning the speakers, use a soft cloth and wipe the surface gently. Do not apply thinner or solvent.
6. Be sure to carefully follow the instructions for:

Cable Connections

Fuse Replacement

Switching the Impedance Selector

Subwoofer Mounting and Smart Trim Ring Installation

Consult Page 15 of this Instruction Manual for details on these procedures.

Dual 4 Ω Application Diagrams

ENGLISH

1 Mono Amplifier
1 Subwoofer
Jumper set to Series
8Ω(4Ω+4Ω) Load

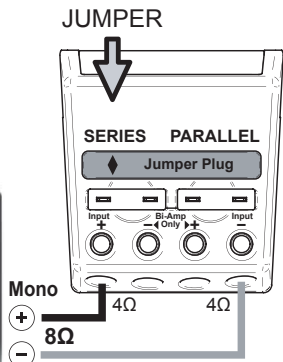

1 Mono Amplifier
1 Subwoofer
Jumper set to Parallel
8Ω(4Ω+4Ω) Load

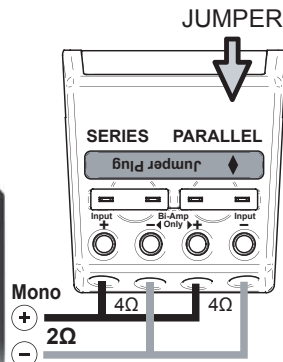

1 2ch Amplifier
1 Subwoofer
Jumper is Removed
4Ω Load

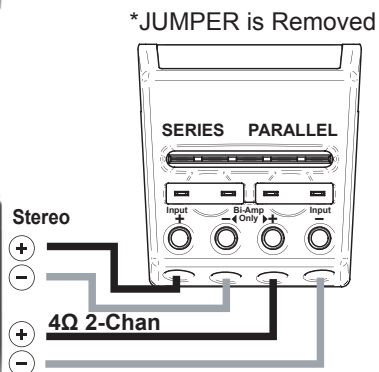

Bi-Amp Configuration 2 Mono Amplifiers
1 Subwoofer Jumper is Removed 4Ω Load

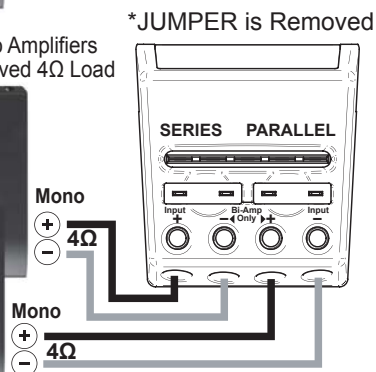

1 Mono Amplifier
2 Subwoofers
Jumper set to Series
Subwoofers wired in Parallel
4Ω Load

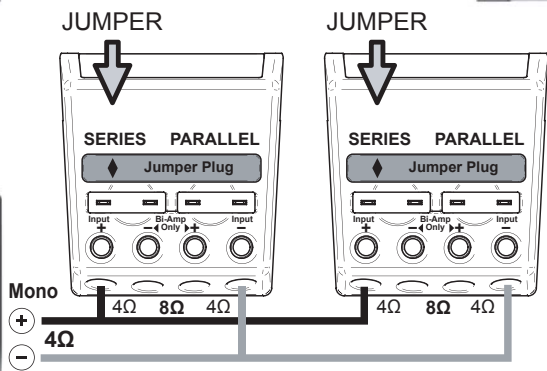

1 Mono Amplifier
3 Subwoofers
Jumper set to Series
Subwoofers wired in Parallel
2.6Ω Load

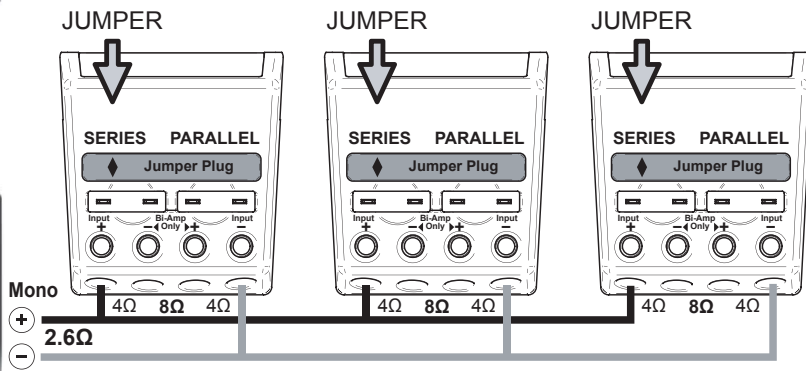

1 Mono Amplifier
4 Subwoofers
Jumper set to Series
Subwoofers wired in Parallel
2Ω Load

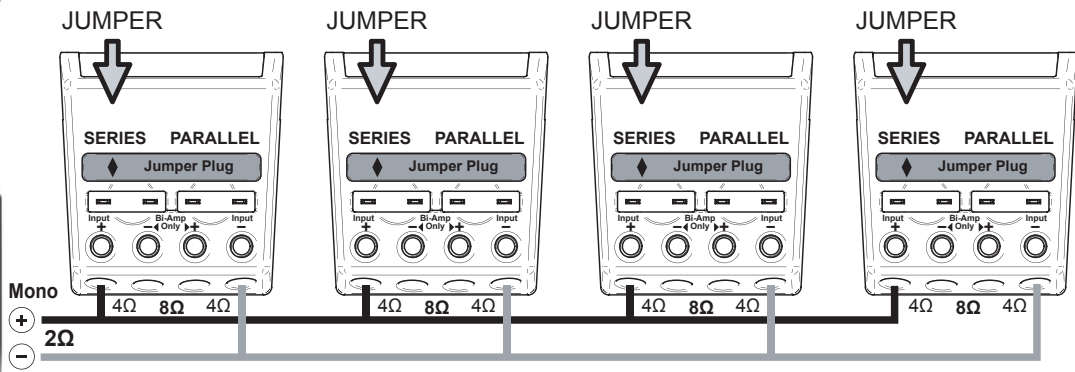

Dual 2 Ω Application Diagrams

1 Mono Amplifier
1 Subwoofer
Jumper set to Series
4Ω(2Ω+2Ω) Load

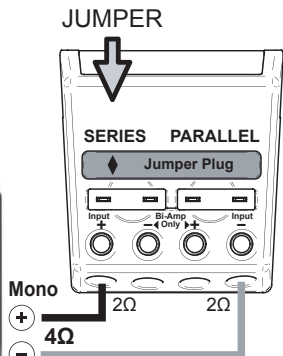

1 Mono Amplifier
1 Subwoofer
Jumper set to Parallel
4Ω(2Ω+2Ω) Load

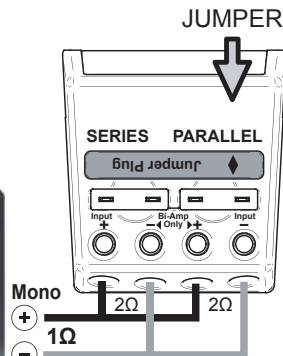

1 2ch Amplifier
1 Subwoofer
Jumper is Removed
2Ω Load

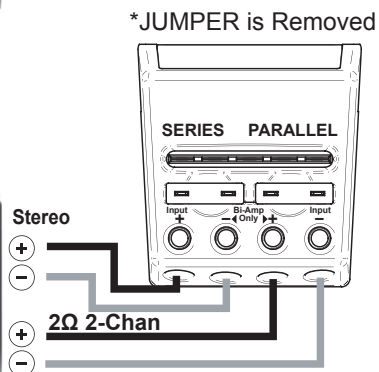

Bi-Amp Configuration 2 Mono Amplifiers
1 Subwoofer Jumper is Removed 2Ω Load

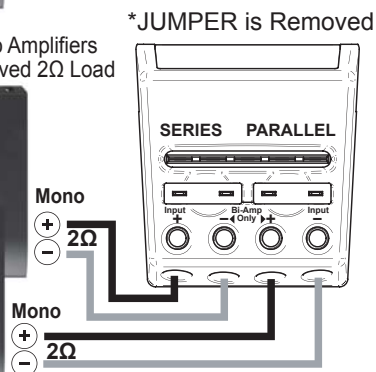

1 Mono Amplifier
2 Subwoofers
Jumper set to Series
Subwoofers wired in Parallel
2Ω Load

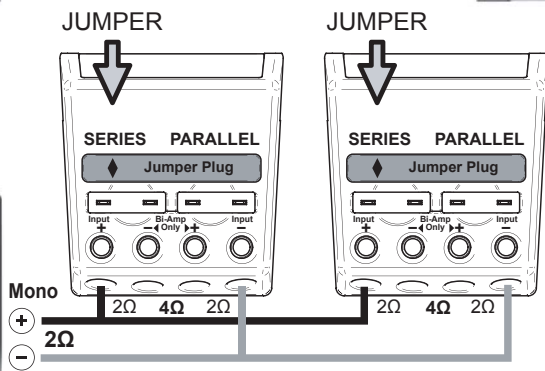

1 Mono Amplifier
3 Subwoofers
Jumper set to Series
Subwoofers wired in Parallel
1.3Ω Load

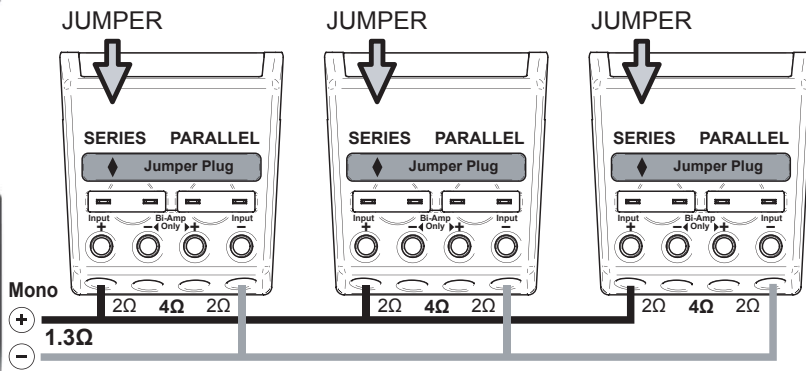

1 Mono Amplifier
4 Subwoofers
Jumper set to Series
Subwoofers wired in Parallel
1Ω Load

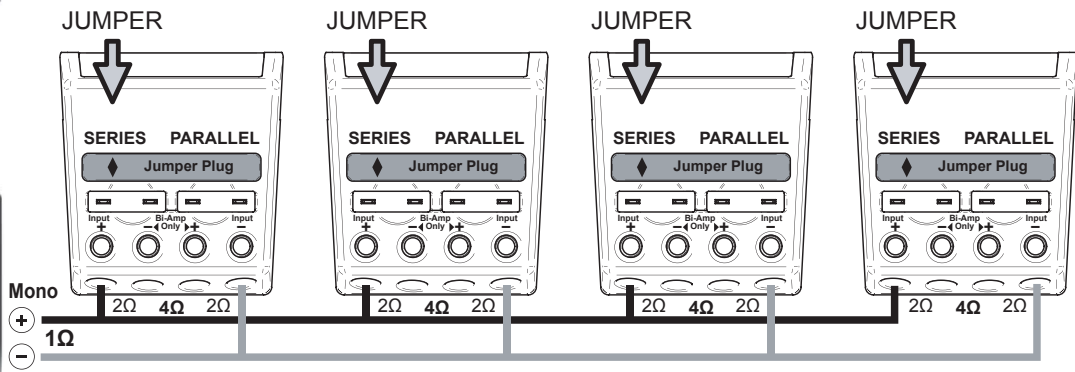

■ To install the sealed enclosure

When the speaker cannot be attached in the car, make the sealed enclosure as recommended in the table below—20 mm (3/4 inch) MDF is also recommended for the enclosure materials.

	CS-AW8520 & 8540
A	26-14/32 inch (671.8 mm)
B	16-28/32 inch (429 mm)
C	10-31/32 inch (278.9 mm)
D	13-26/32 inch (351.2 mm)
E	13-18/32 inch (370mm)
F	4/32 inch (3 mm)
G	2.205 ft ³ (0.062 m ³)

Front & Rear Baffle Boards (x 2)

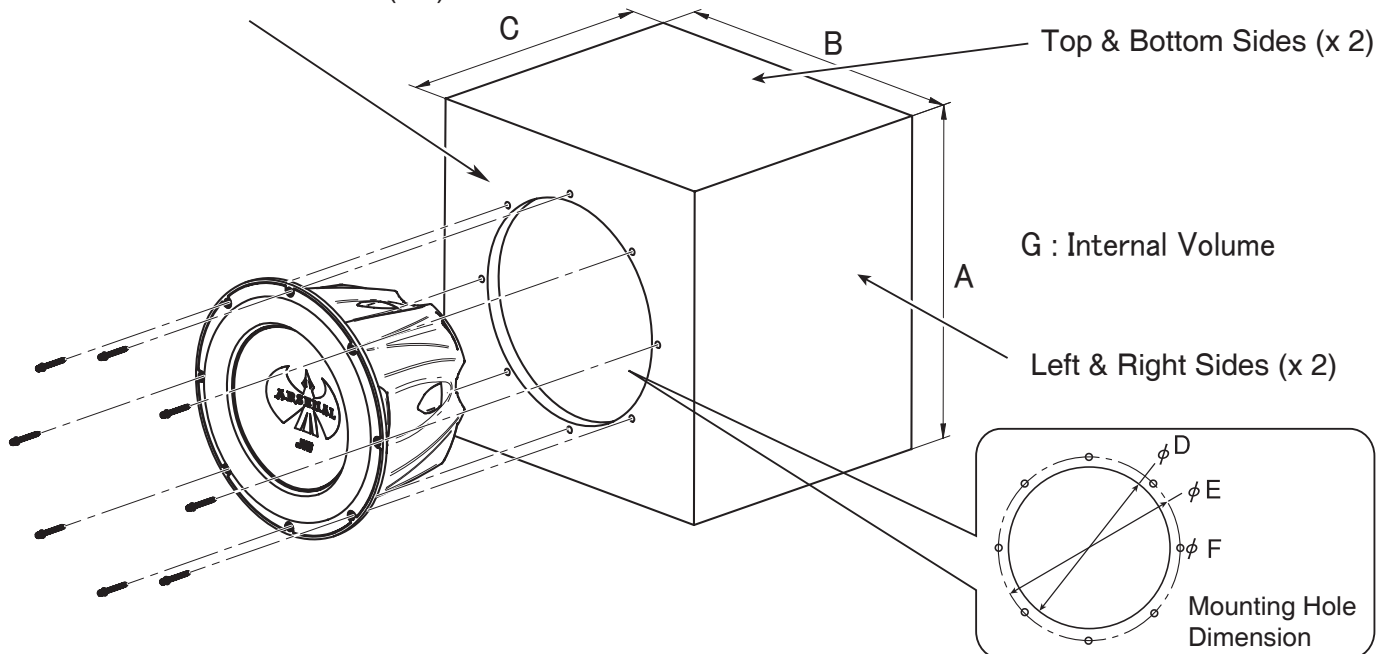

* Screw: Dia. 4mm x 50mm (x 8) (supplied)

■ To install the ported enclosure

When the speaker cannot be attached in the car, make the sealed enclosure as recommended in the table below—20 mm (3/4 inch) MDF is also recommended for the enclosure materials.

	CS-AW8520 & 8540
A	26-14/32 inch (671.8 mm)
B	16-28/32 inch (429 mm)
C	10-31/32 inch (278.9 mm)
D	13-26/32 inch (351.2 mm)
E	13-18/32 inch (370mm)
F	4/32 inch (3 mm)
G	3 inch (76.2 mm)
H	9 inch (228.6 mm)
I	21 inch (533.4 mm)
J	3.255 ft ³ (0.092 m ³)

Front & Rear Baffle Boards (x 2)

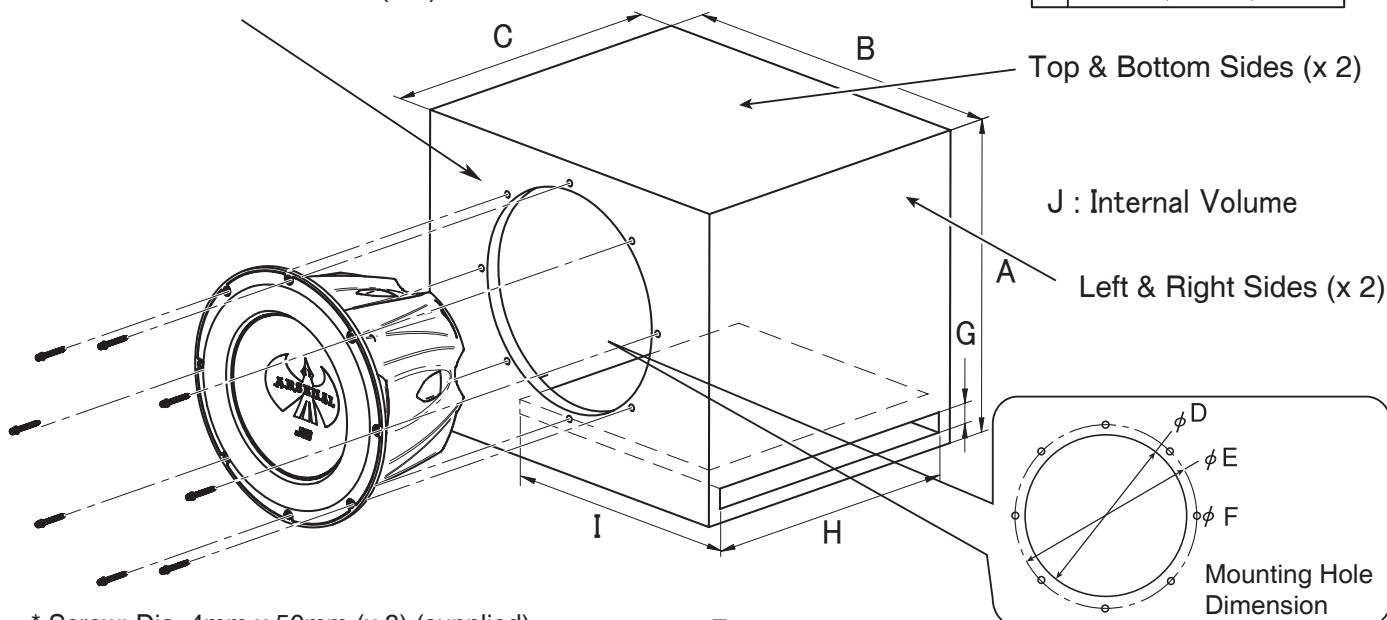

* Screw: Dia. 4mm x 50mm (x 8) (supplied)

Parameters	CS-AW8520		CS-AW8540		NOTES
	parallel	series	parallel	series	
Nominal Impedance (Ω)	2 Ω + 2 Ω		4 Ω + 4 Ω		
SPL (dB,1W/1M)	88.09 dB	88.23 dB	88.37 dB	88.44dB	SPL : Sound pressure level
Displacement (Liter)	0.403 ft ³		0.403 ft ³		
Hole Cutout Diameter (inch) (mm)	Dia. 13 - 30/32 inch (354 mm)		Dia. 13 - 30/32 inch (354 mm)		
Mounting Depth (inch) (mm)	9 - 22/32 inch (245.85 mm)		9 - 22/32 inch (245.85 mm)		
Re (Ω)	1.03 Ω	3.99 Ω	2.08 Ω	8.20 Ω	Re : DC voice coil resistance
BL (T.M)	10.71	21.39	14.38	28.78	BL : Product of Flux density and Effective Voicecoil-wire length
Vas (Liter)	88.99 L	89.16 L	95.157 L	95.445 L	Vas : Volume of air equal to the driver compliance
Vas (CuFt)	3.14 ft ³	3.14 ft ³	3.36 ft ³	3.37 ft ³	
Me (g)	299.92 g	299.10 g	274.15 g	274.04 g	Me : Effective mass
D (mm)	Dia. 253 mm		Dia. 253 mm		D : Effective cone diameter
Fs (Hz)	27.7 Hz	27.7 Hz	28.0 Hz	27.9 Hz	Fs : Driver free air resonance
Qms	6.396	6.413	5.517	5.472	Qms : Q of driver at Fs considering only non-electrical resistance
Qes	0.466	0.453	0.483	0.476	Qes : Q of driver at Fs considering only electrical resistance
Qts	0.434	0.423	0.445	0.438	Qts : Total Q of driver at Fs
Pe [max.] (W)	1500 W		1500 W		Pe[max.] : Maximum continuous input power
Xmax.(mm)	24.7 mm		23.7 mm		Xmax. : Maximum effective voicecoil travel without distortion
Freq.Responce (Hz)	28 ~500 Hz		29 ~500 Hz		
Magnet Mass (oz) (g)	308.94 oz (8757.96 g)		308.94 oz (8757.96 g)		
Voice Coil(Aluminum)Dia.(inch) (mm)	Dia. 3 - 7/32 inch (80.54 mm)		Dia. 3 - 7/32 inch (80.54 mm)		
Hvc (mm)	51.6 mm		51.6 mm		Hvc : Voice coil Height
Hag (mm)	10 mm		10 mm		Hag : Gap Height

Nous vous remercions pour l'achat d'un haut-parleur auto stéréo de ARSENAL dans le coffre de votre véhicule. Pour un montage sûr et un fonctionnement parfait de ce haut-parleur, il est conseillé de lire attentivement ce qui suit.

Parts

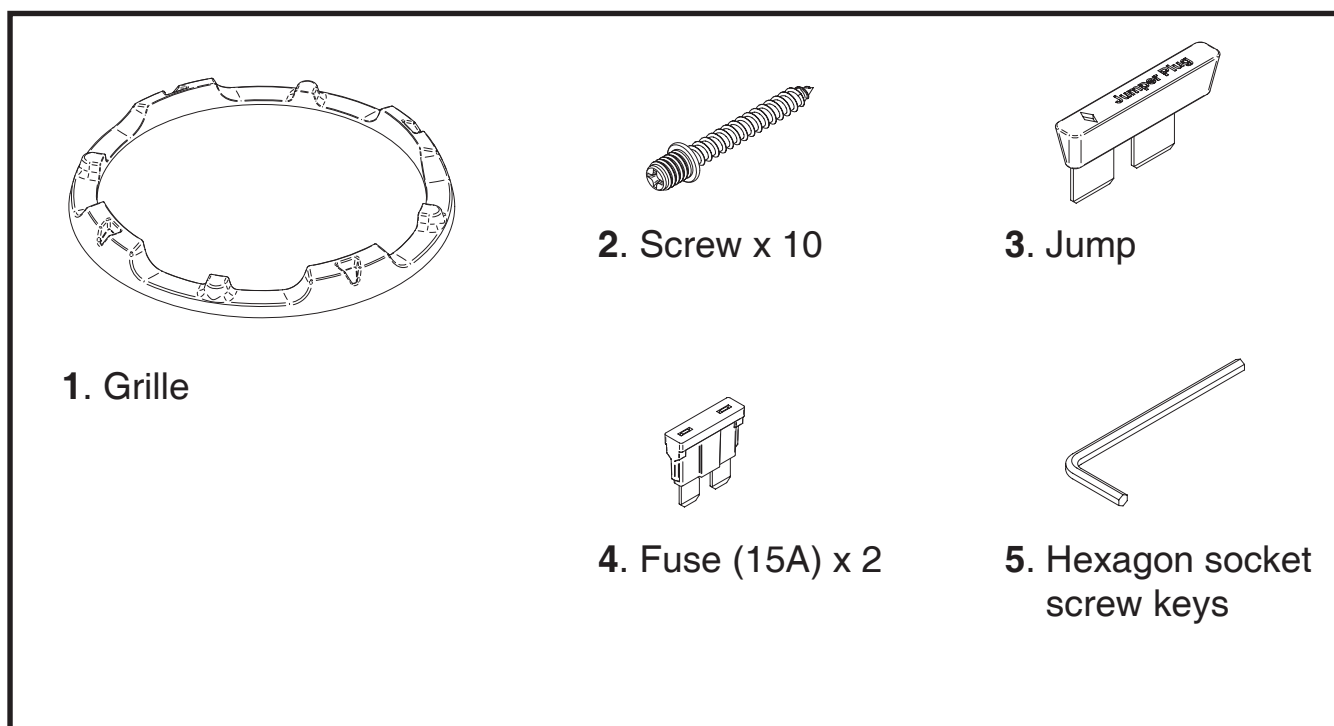

Montage et utilisation corrects

1. Vérifier que l'alimentation est coupée avant de raccorder les haut-parleurs à l'amplificateur. Les craquements produits par le raccordement lors que l'alimentation est fournie peuvent endommager les haut-parleurs.
2. Raccorder les bornes correspondantes de l'amplificateur et les haut-parleurs, c'est-à-dire, gauche à gauche, droit à droite, de même que "+" à "+" et "-" à "-". Un raccordement effectué en inversant les polarités réduira la qualité de la reproduction sonore stéréo-phonique.
3. Ne pas appliquer un niveau d'entrée excessif aux haut-parleurs. La puissance d'entrée admissible pour les haut-parleurs CS-AW8520/CS-AW8540 est de 1500 watts (puissance musicale R.M.S.). Tout signal d'entrée excessif risque de les endommager.
4. Les haut-parleurs CS-AW8520/CS-AW8540 ont une impédance de 2Ω, 4Ω, 8Ω. Il faut par conséquent s'assurer que l'impédance de sortie aux bornes de haut-parleur de l'amplificateur soit aussi de 2Ω, 4Ω, 8Ω.
5. Nettoyer le haut-parleur en le frottant légèrement à l'aide d'un chiffon doux. Ne jamais utiliser de solvants ni de détergents.
6. Veuillez suivre attentivement les instructions suivantes pour:

Connections de Câble

Remplacement de Fusible

Changement de la Sélection d'Impédance

Montage du Subwoofer et Installation Pratique de la Moulure de Finition

Consultez la Page 15 de ce Manuel d'Instruction pour les détails de ces procédures.

Diagrammes d'application duale 4Ω

FRANÇAIS

1 amplificateur mono
1 (un) caisson de basse
Cavalier branché en Série
Impédance de charge de
 $8\Omega(4\Omega+4\Omega)$

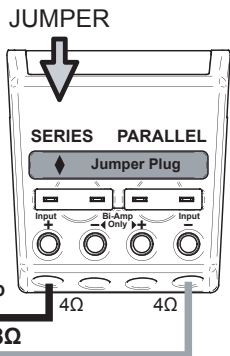

1 amplificateur mono
1 (un) caisson de basse
Cavalier branché en Parallèle
Impédance de charge de
 $8\Omega(4\Omega+4\Omega)$

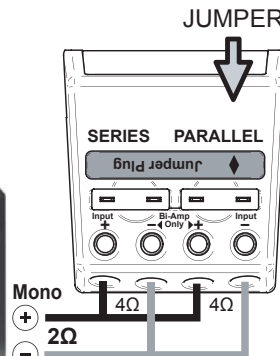

1 amplificateur mono
1 (un) caisson de basse
Cavalier branché en Parallèle
Impédance de charge de $8\Omega(4\Omega+4\Omega)$

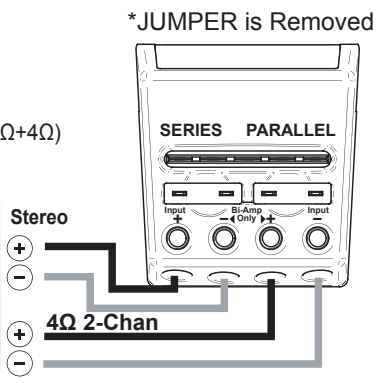

Configuration en double amplification
2 amplificateurs mono
1 (un) caisson de basse Cavalier débranché
Impédance de charge de 4Ω

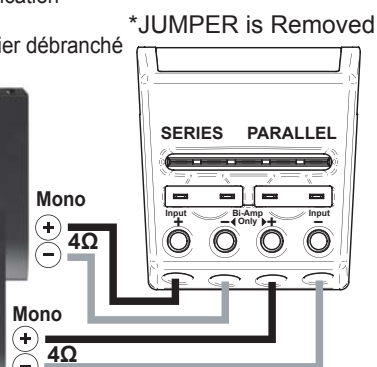

1 amplificateur mono
2 (deux) caissons de basse
Cavalier branché en Série
Subwoofers wired in Parallel
Impédance de charge de 4Ω

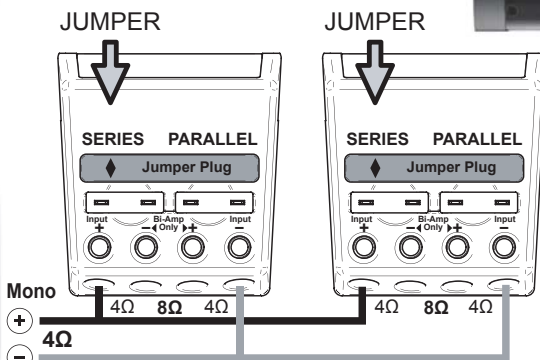

1 amplificateur mono
3 (trois) caissons de basse
Cavalier branché en Série
Subwoofers wired in Parallel
Impédance de charge de 2.6Ω

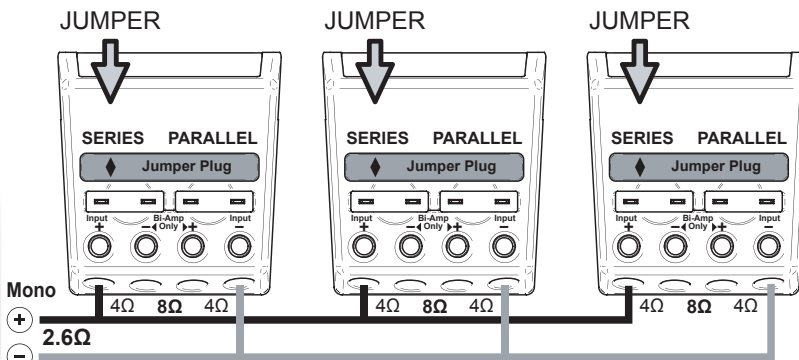

1 amplificateur mono
4 (quatre) caissons de basse
Cavalier branché en Série
Subwoofers wired in Parallel
Impédance de charge de 2Ω

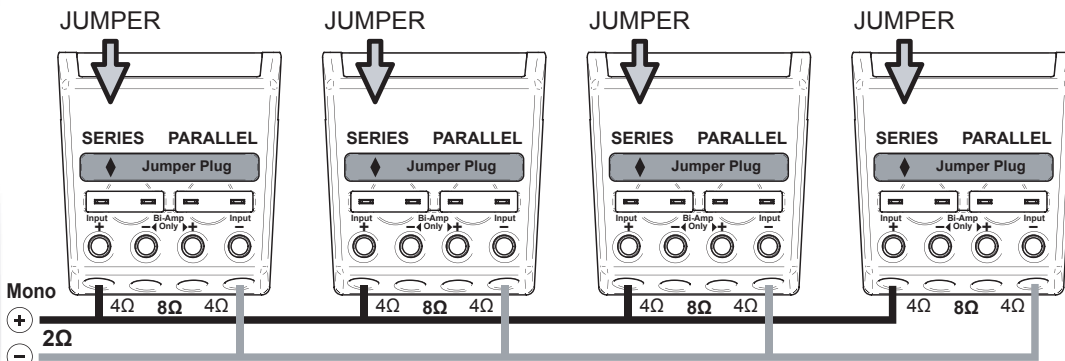

Diagrammes d'application duale 2Ω

FRANÇAIS

1 amplificateur mono
1 (un) caisson de basse
Cavalier branché en Série
Impédance de charge de $4\Omega(2\Omega+2\Omega)$

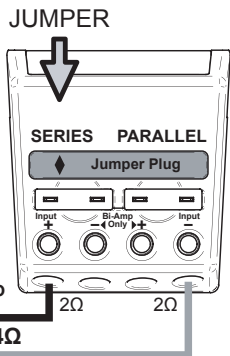

1 amplificateur mono
1 (un) caisson de basse
Cavalier branché en Parallèle
Impédance de charge de $4\Omega(2\Omega+2\Omega)$

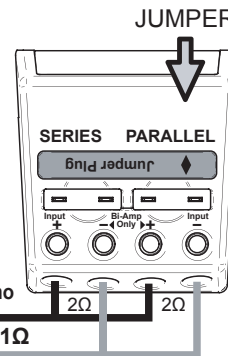

1 amplificateur mono
1 (un) caisson de basse
Cavalier branché en Parallèle
Impédance de charge de $4\Omega(2\Omega+2\Omega)$

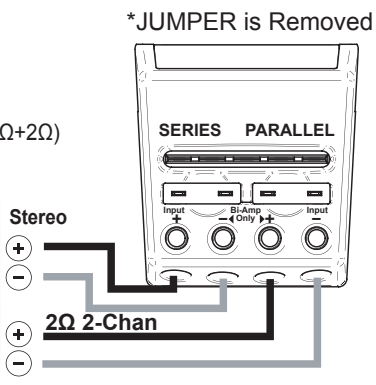

Configuration en double amplification
2 amplificateurs mono
1 (un) caisson de basse Cavalier débranché
Impédance de charge de 2Ω

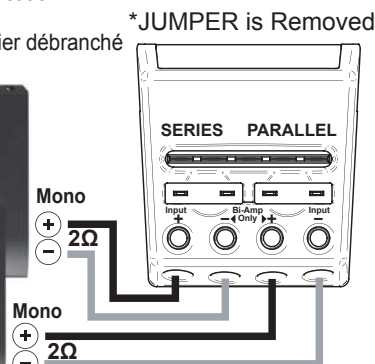

1 amplificateur mono
2 (deux) caissons de basse
Cavalier branché en Série
Subwoofers wired in Parallel
Impédance de charge de 2Ω

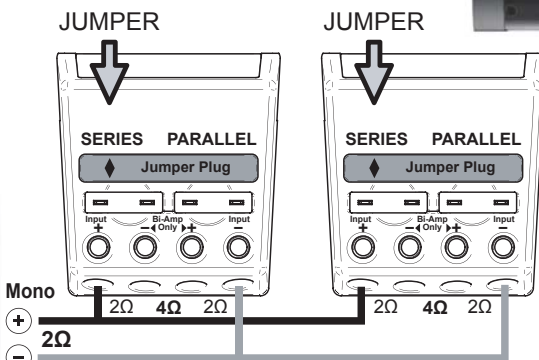

1 amplificateur mono
3 (trois) caissons de basse
Cavalier branché en Série
Subwoofers wired in Parallel
Impédance de charge de 1.3Ω

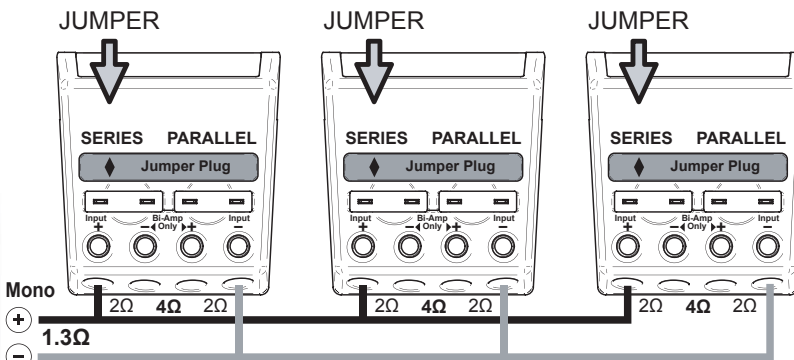

1 amplificateur mono
4 (quatre) caissons de basse
Cavalier branché en Série
Subwoofers wired in Parallel
Impédance de charge de 1Ω

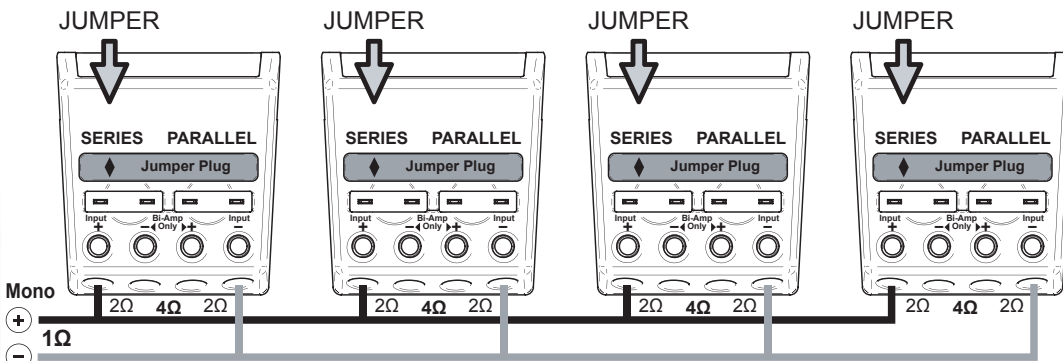

■ Pour installer l'enceinte hermétique

Si le haut-parleur ne peut pas être fixé directement dans cette voiture, fabriquez une enceinte hermétique de façon recommandée à l'aide des spécifications données dans le tableau ci-dessous; le MDF—20 mm (3/4 pouce) est recommandé pour le matériau de l'enceinte.

CS-AW8520 & 8540	
A	26-14/32 inch (671.8 mm)
B	16-28/32 inch (429 mm)
C	10-31/32 inch (278.9 mm)
D	13-26/32 inch (351.2 mm)
E	13-18/32 inch (370mm)
F	4/32 inch (3 mm)
G	2.205 ft ³ (0.062 m ³)

Écrans acoustiques avant et arrière (x 2)

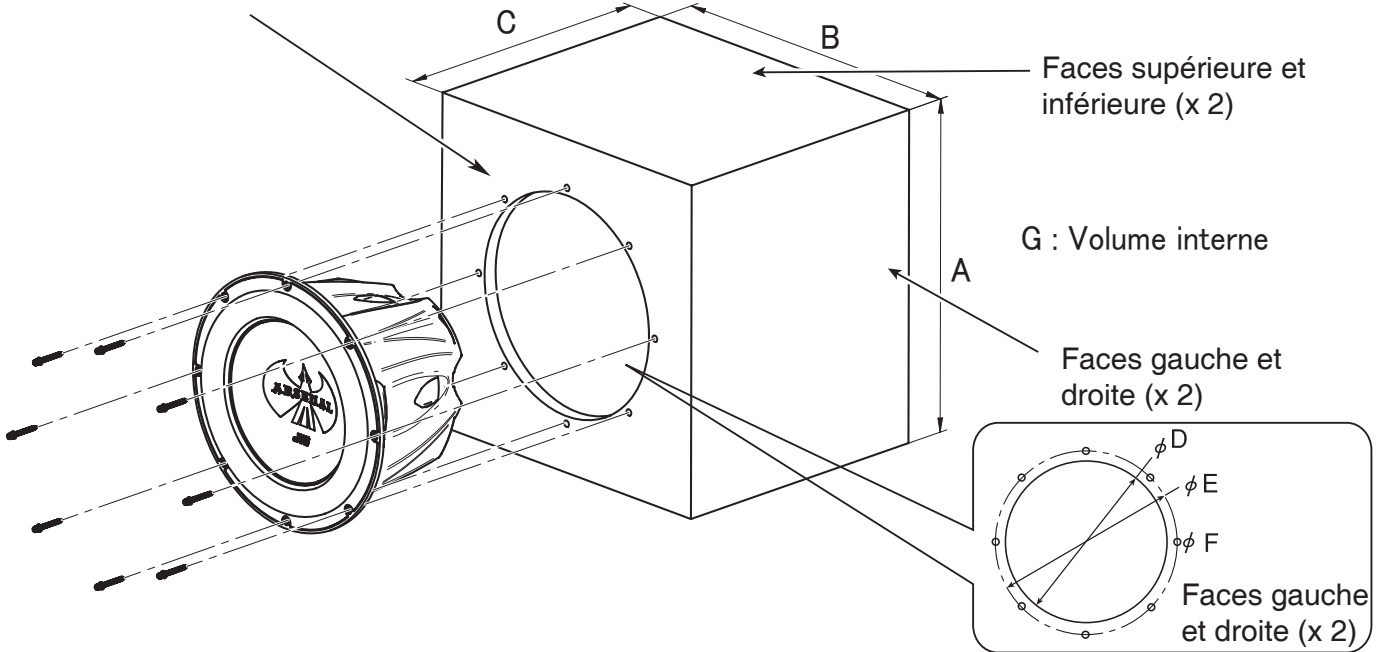

Faces supérieure et inférieure (x 2)

G : Volume interne

Faces gauche et droite (x 2)

Faces gauche et droite (x 2)

* Vis: Dia. 4mm x 50mm (x 8) (fournis)

■ Pour installer l'enceinte hermétique

Si le haut-parleur ne peut pas être fixé directement dans cette voiture, fabriquez une enceinte hermétique de façon recommandée à l'aide des spécifications données dans le tableau ci-dessous; le MDF—20 mm (3/4 pouce) est recommandé pour le matériau de l'enceinte.

CS-AW8520 & 8540	
A	26-14/32 inch (671.8 mm)
B	16-28/32 inch (429 mm)
C	10-31/32 inch (278.9 mm)
D	13-26/32 inch (351.2 mm)
E	13-18/32 inch (370mm)
F	4/32 inch (3 mm)
G	3 inch (76.2 mm)
H	9 inch (228.6 mm)
I	21 inch (533.4 mm)
J	3.255 ft ³ (0.092 m ³)

Écrans acoustiques avant et arrière (x 2)

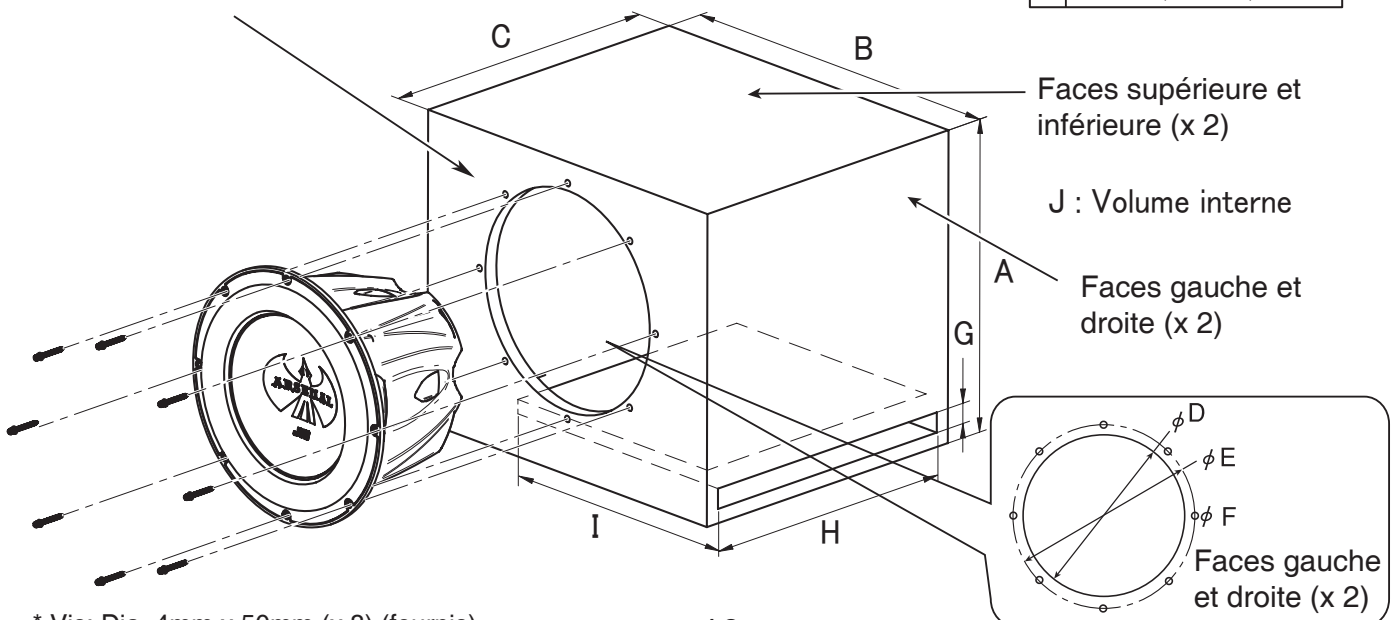

Faces supérieure et inférieure (x 2)

J : Volume interne

Faces gauche et droite (x 2)

Faces gauche et droite (x 2)

* Vis: Dia. 4mm x 50mm (x 8) (fournis)

Paramètres	CS-AW8520		CS-AW8540		REMARQUES
	parallel	series	parallel	series	
Impédance nominale (Ω)	2 Ω + 2 Ω		4 Ω + 4 Ω		
SPL (dB,1W/1M)	88.09 dB	88.23 dB	88.37 dB	88.44dB	SPL : Niveau de pression sonore
Déplacement (Liter)	0.403 ft ³		0.403 ft ³		
Diamètre du tuou de découpe (pouces) (mm)	Dia. 13 - 30/32 inch (354 mm)		Dia. 13 - 30/32 inch (354 mm)		
Profondeur de montage (pouces) (mm)	9 - 22/32 inch (245.85 mm)		9 - 22/32 inch (245.85 mm)		
Re (Ω)	1.03 Ω	3.99 Ω	2.08 Ω	8.20 Ω	Re : Résistance de la bobine mobile en CC
BL (T.M)	10.71	21.39	14.38	28.78	BL : Produit de la densité de flux et de la longueur efficace de fil de la bobine mobile
Vas (litre)	88.99 L	89.16 L	95.157 L	95.445 L	Vas : Volume d'air égal à la conformité de l'excitateur
Vas (CuFt)	3.14 ft ³	3.14 ft ³	3.36 ft ³	3.37 ft ³	
Me (g)	299.92 g	299.10 g	274.15 g	274.04 g	Me : Masse effective
D (mm)	Dia. 253 mm		Dia. 253 mm		D : Diamètre effectif du cône
Fs (Hz)	27.7 Hz	27.7 Hz	28.0 Hz	27.9 Hz	Fs : Résonance à l'air libre de l'excitateur
Qms	6.396	6.413	5.517	5.472	Qms : Q de l'excitateur à Fs considérant uniquement la résistance non-électrique
Qes	0.466	0.453	0.483	0.476	Qes : Q de l'excitateur à Fs considérant uniquement la résistance électrique
Qts	0.434	0.423	0.445	0.438	Qts : Q total de l'excitateur à Fs
Pe [max.] (W)	1500 W		1500 W		Pe[max.] : Puissance d'entrée continue maximum
Xmax. (mm)	24.7 mm		23.7 mm		Xmax. : Déplacement effectif maximum de la bobine mobile sans distorsion
Réponse en fréquence (Hz)	28 ~500 Hz		29 ~500 Hz		
Masse de l'aimant (once) (g)	308.94 oz (8757.96 g)		308.94 oz (8757.96 g)		
Diamètre de la bobine mobile (pouces) (mm)	Dia. 3 - 7/32 inch (80.54 mm)		Dia. 3 - 7/32 inch (80.54 mm)		
Hvc (mm)	51.6 mm		51.6 mm		Hvc : Hauteur de la bobine mobile
Hag (mm)	10 mm		10 mm		Hvc : Hauteur de la bobine mobile

Le agradecemos la adquisición del Altavoz Estereofónico para Automóvil de ARSENAL. Para efectuar una instalación segura y para que el altavoz funcione correctamente, lea detenidamente las siguientes instrucciones.

Parts

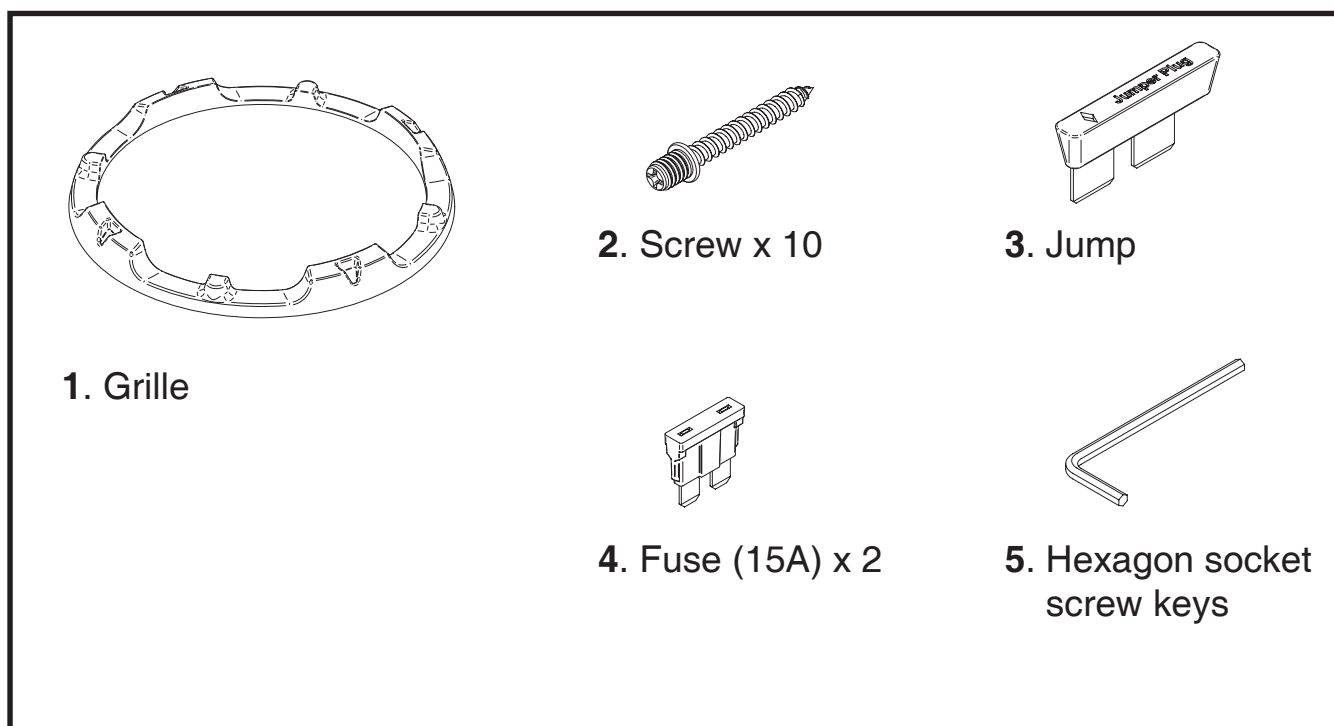

Instalación y uso correctos

1. Antes de conectar los altavoces con el amplificador, confirme que esté cortada la alimentación eléctrica. El ruido producido al realizar la conexión con la alimentación conectada puede causar daños en los altavoces.
2. Deben conectarse los terminales correspondientes del amplificador y de los altavoces, es decir izquierdo a izquierdo y derecho a derecho, así como “+” a “+” y “-” a “-”. Si las polaridades se conectan inversamente, la reproducción estereofónica se deteriorará.
3. No someta los altavoces a una entrada excesiva. La capacidad máxima de los CS-AW8520/CS-AW8540 es de 1500 vatios (POTENCIA MUSICAL R.M.S.). Una entrada excesiva dañará los altavoces.
4. Los CS-AW8520/CS-AW8540 tienen 2Ω, 4Ω, 8Ω de impedancia. Asegúrese de que la impedancia de salida del terminal para altavoces de amplificador sea de 2Ω, 4Ω, 8Ω.
5. Cuando limpie los altavoces, utilice un paño suave y frote la superficie con cuidado. No aplique solventes ni diluyentes.
6. Asegúrese de seguir cuidadosamente las instrucciones para:

Conecciones de Cable

Reemplazo de fusible

Cambiando el Selector de Resistencia

Instalar el subwoofer y la moldura del anillo

Consulte la Page 15 de este Manual de Instrucciones para los detalles de estos procedimientos.

Diagramas de Aplicacion Dual 4Ω

1 amplificador monofónico
1(un) bajo
Puente fijado en serie
Carga a 8Ω(4Ω+4Ω)

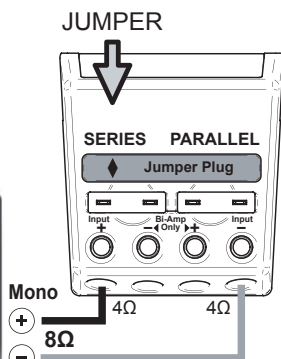

1 amplificador monofónico
1(un) bajo
Puente fijado en Paralelo
Carga a 8Ω(4Ω+4Ω)

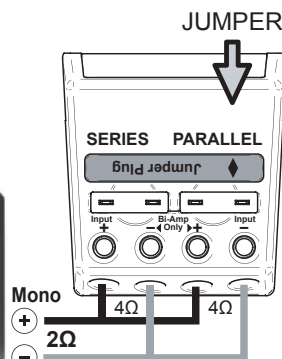

Amplificador 1,2 ch
1(un) bajo
Se quita el puente
Carga a 4Ω

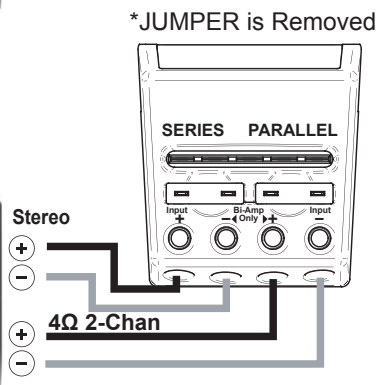

Configuracion Bi-Amplificada
2 amplificadores monofónicos
1(un) bajo Se quita el puente Carga a 4Ω

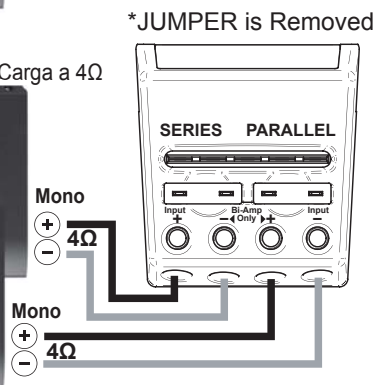

1 amplificador monofónico
2 (Dos) bajos
Puente fijado en serie
Subwoofers wired in Parallel
Carga a 4Ω

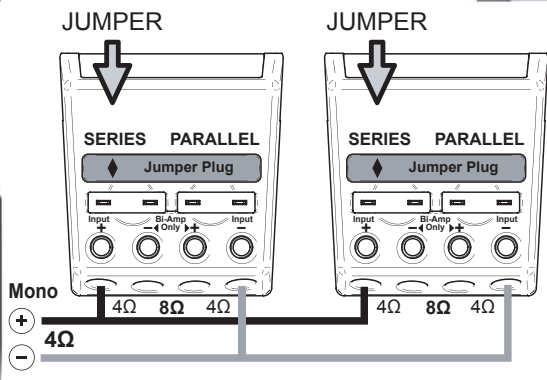

1 amplificador monofónico
3 (Tres) bajos
Puente fijado en serie
Subwoofers wired in Parallel
Carga a 2.6Ω

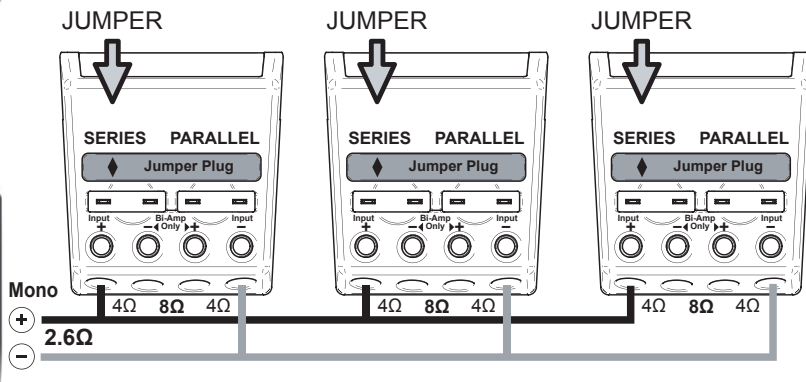

1 amplificador monofónico
4 (Cuatro) bajos
Puente fijado en serie
Subwoofers wired in Parallel
Carga a 2Ω

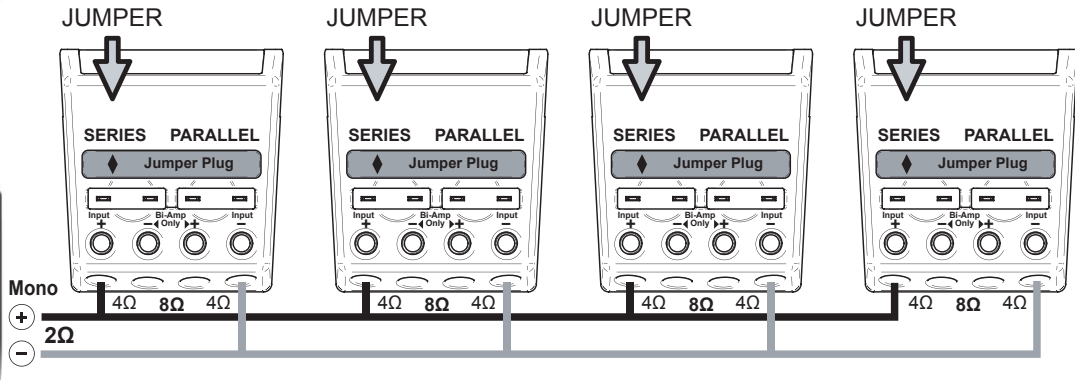

ESPAÑOL

Diagramas de Aplicacion Dual 2Ω

ESPAÑOL

1 amplificador monofónico
1(un) bajo
Puente fijado en serie
Carga a 4Ω(2Ω+2Ω)

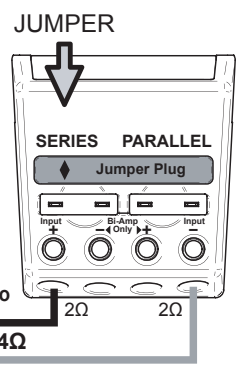

1 amplificador monofónico
1(un) bajo
Puente fijado en Paralelo
Carga a 4Ω(2Ω+2Ω)

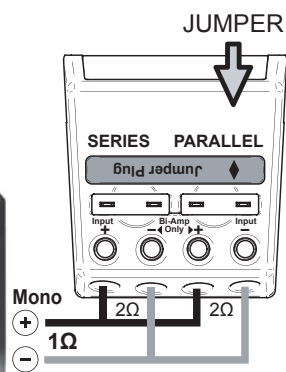

Amplificador 1,2 ch
1(un) bajo
Se quita el puente
Carga a 2Ω

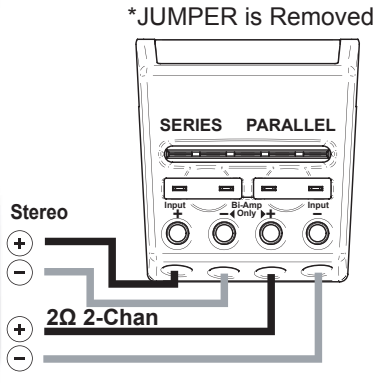

Configuracion Bi-Amplificada
2 amplificadores monofónicos
1(un) bajo Se quita el puente Carga a 2Ω

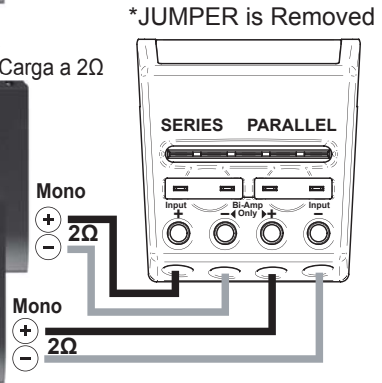

1 amplificador monofónico
2 (Dos) bajos
Puente fijado en serie
Subwoofers wired in Parallel
Carga a 2Ω

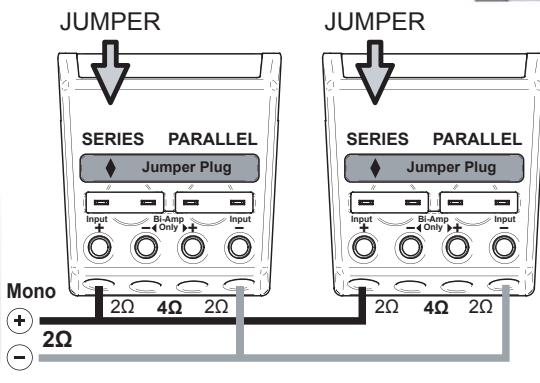

1 amplificador monofónico
3 (Tres) bajos
Puente fijado en serie
Subwoofers wired in Parallel
Carga a 1.3Ω

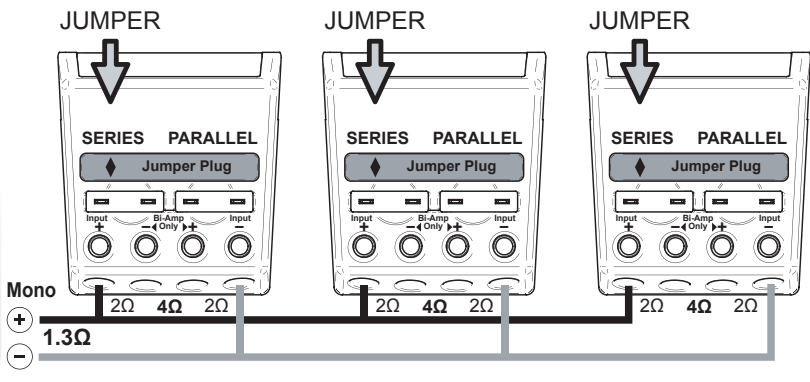

1 amplificador monofónico
4 (Cuatro) bajos
Puente fijado en serie
Subwoofers wired in Parallel
Carga a 1Ω

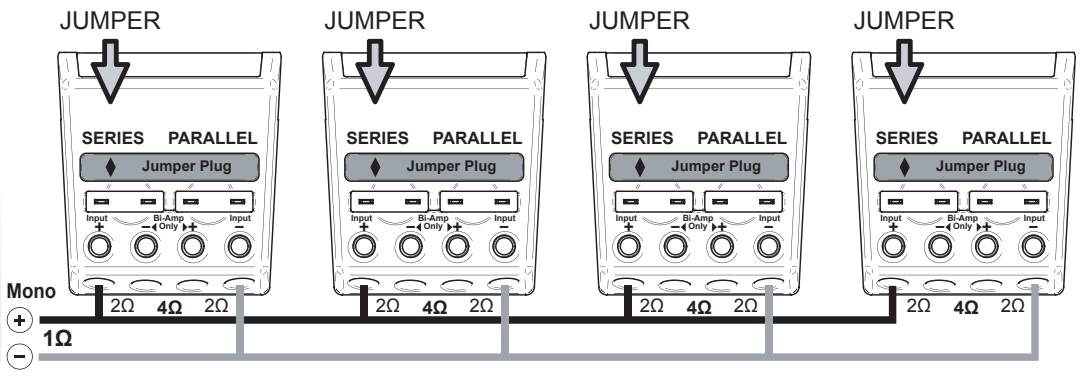

Para instalar la caja sellada

Cuando el altavoz no se pueda instalar en el automóvil, construya la caja sellada recomendada en la tabla de abajo—Asimismo, se recomienda usar MDF—20 mm (3/4 pulg.) como material para la caja.

CS-AW8520 & 8540	
A	26-14/32 inch (671.8 mm)
B	16-28/32 inch (429 mm)
C	10-31/32 inch (278.9 mm)
D	13-26/32 inch (351.2 mm)
E	13-18/32 inch (370mm)
F	4/32 inch (3 mm)
G	2.205 ft ³ (0.062 m ³)

Pantallas acústicas delantera y trasera (x 2)

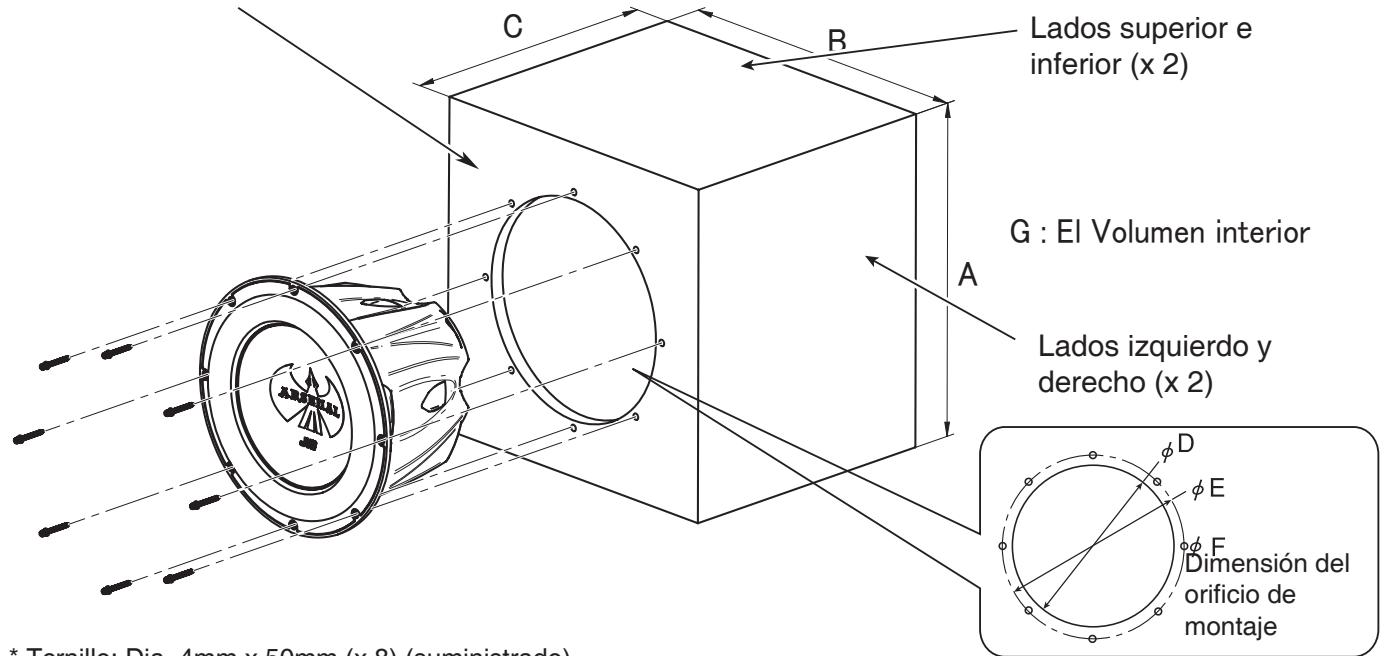

* Tornillo: Dia. 4mm x 50mm (x 8) (suministrado)

Para instalar la caja sellada

Cuando el altavoz no se pueda instalar en el automóvil, construya la caja sellada recomendada en la tabla de abajo—Asimismo, se recomienda usar MDF—20 mm (3/4 pulg.) como material para la caja.

CS-AW8520 & 8540	
A	26-14/32 inch (671.8 mm)
B	16-28/32 inch (429 mm)
C	10-31/32 inch (278.9 mm)
D	13-26/32 inch (351.2 mm)
E	13-18/32 inch (370mm)
F	4/32 inch (3 mm)
G	3 inch (76.2 mm)
H	9 inch (228.6 mm)
I	21 inch (533.4 mm)
J	3.255 ft ³ (0.092 m ³)

Pantallas acústicas delantera y trasera (x 2)

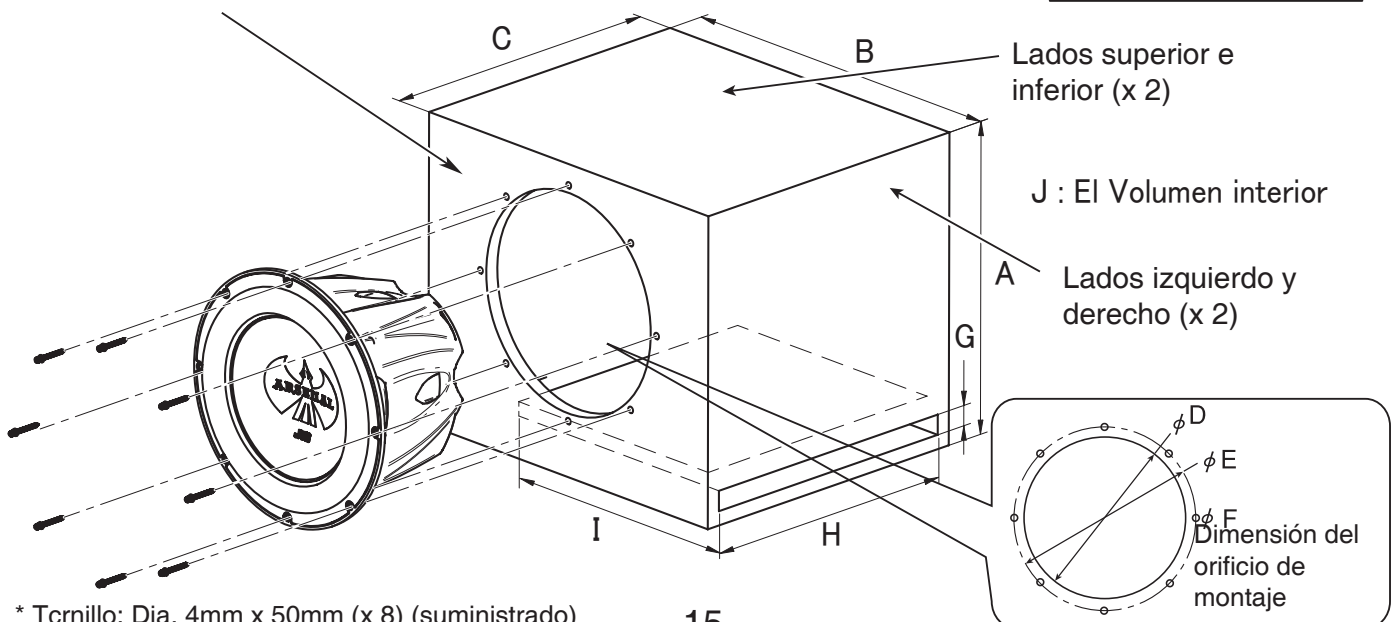

* Tornillo: Dia. 4mm x 50mm (x 8) (suministrado)

Parámetros	CS-AW8040		CS-AW8240		NOTAS
	parallel	series	parallel	series	
Impedancia nominal (Ω)	2 Ω + 2 Ω		4 Ω + 4 Ω		
SPL (dB,1W/1M)	88.09 dB	82.65 dB	86.14 dB	86.27dB	SPL : Nivel de presión de sonido
Desplazamiento (litro)	0.403 ft ³		0.403 ft ³		
Diámetro del orificio cortado (pulgada) (mm)	Dia. 13 - 30/32 inch (354 mm)		Dia. 13 - 30/32 inch (354 mm)		
Profundidad de montaje (pulgada) (mm)	9 - 22/32 inch (245.85 mm)		9 - 22/32 inch (245.85 mm)		
Re (Ω)	1.03 Ω	3.99 Ω	2.07 Ω	8.17 Ω	Re : Resistencia de la bobina móvil de CC
BL (T.M)	10.71	21.39	11.5	22.85	BL : Producto de densidad de flujo y longitud efectiva del cable de la bobina móvil
Vas (litro)	88.99 L	89.16 L	160.534 L	106.92 L	Vas: Volumen de aire equivalente en conformidad con el excitador
Vas (pies cúbicos)	3.14 ft ³	3.14 ft ³	3.78 ft ³	3.8 ft ³	
Me (g)	128.94 g	126.28 g	257.37 g	267.4 g	Me : Masa efectiva
D (mm)	Dia. 253 mm		Dia. 253 mm		D : Diámetro efectivo del cono
Fs (Hz)	27.7 Hz	27.7 Hz	26.7 Hz	26.7 Hz	Fs : Resonancia del aire sin excitador
Qms	6.396	6.413	6.507	6.381	Qms : Q del excitador a Fs considerando sólo la resistencia no eléctrica
Qes	0.466	0.453	0.69	0.71	Qes : Q del excitador a Fs considerando sólo la resistencia eléctrica
Qts	0.434	0.423	0.67	0.68	Qts : Total Q dei excitador a Fs
Pe [máx.] (W)	1500 W		1500 W		Pe[max.] : Potencia máxima de entrada continua
Xmax. (mm)	20.8 mm		20.8 mm		Xmax. : Máximo desplazamiento efectivo de la bobina móvil sin distorsón
Respuesta de frec (Hz)	30 ~500 Hz		30 ~500 Hz		
Masa del imán (oz) (g)	308.94 oz (8757.96 g)		308.94 oz (8757.96 g)		
Diám.de la bobina móvil (pulgada) (mm)	Dia. 3 - 7/32 inch (80.54 mm)		Dia. 3 - 7/32 inch (80.54 mm)		
Hvc (mm)	51.6 mm		51.6 mm		Hvc : Altura de bobina móvil
Hag (mm)	10 mm		10 mm		Hag : Altura de entrehierro

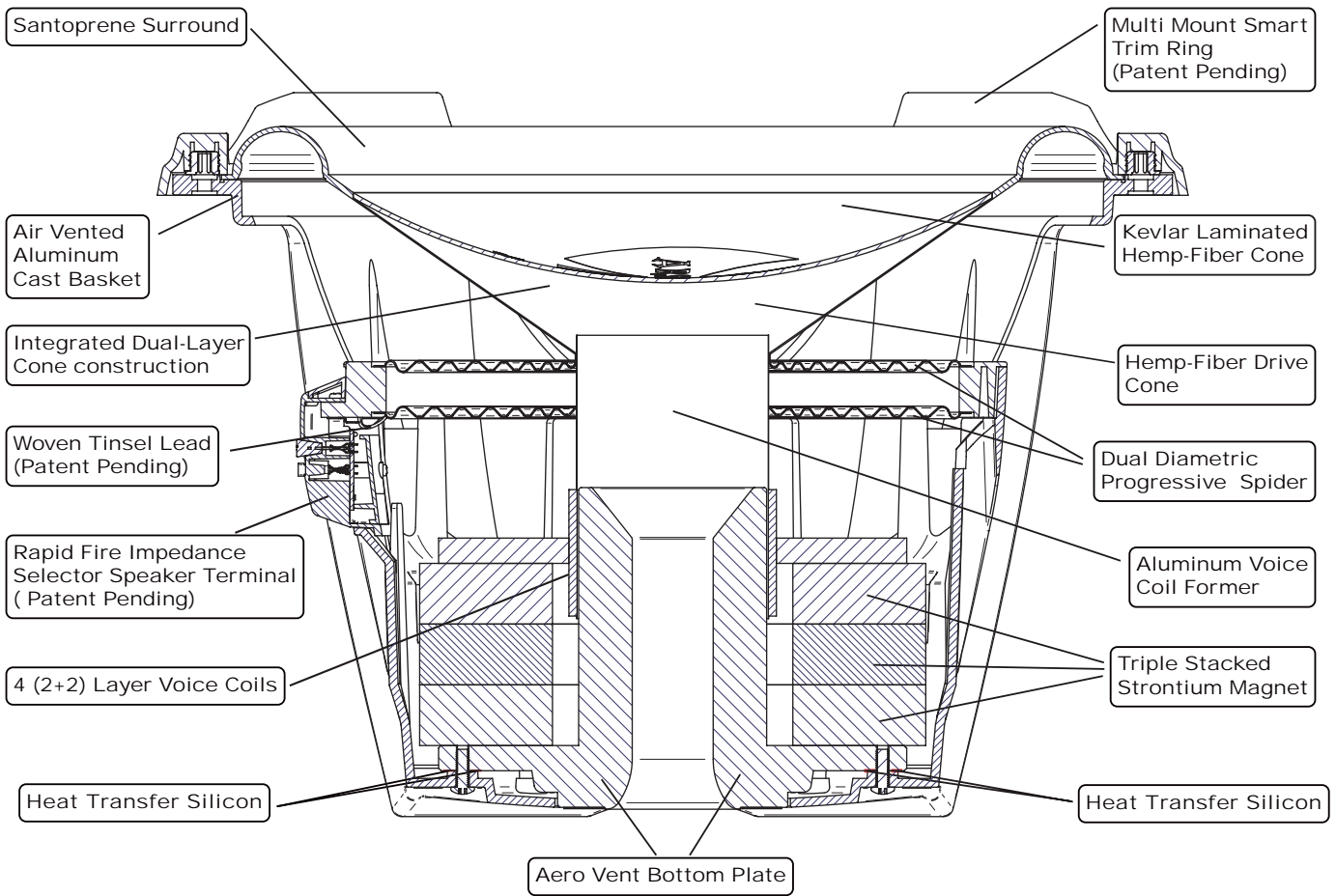

T3 Chassis (Thermal Transfer Technology)

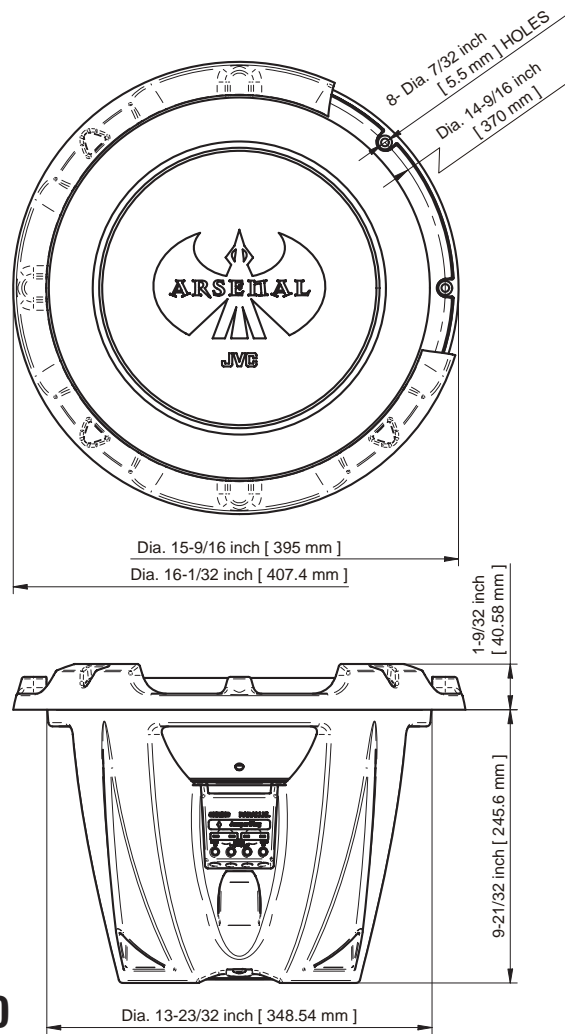

CS-AW8520 & 8540

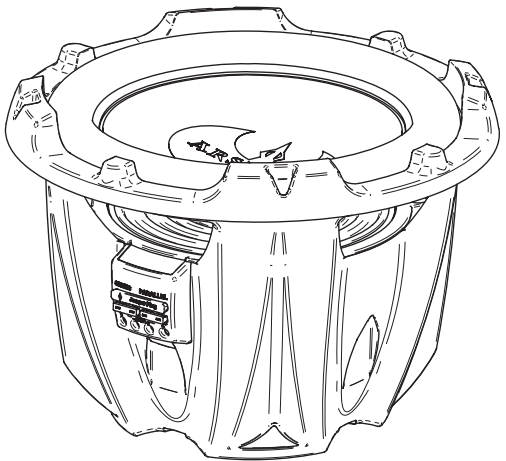
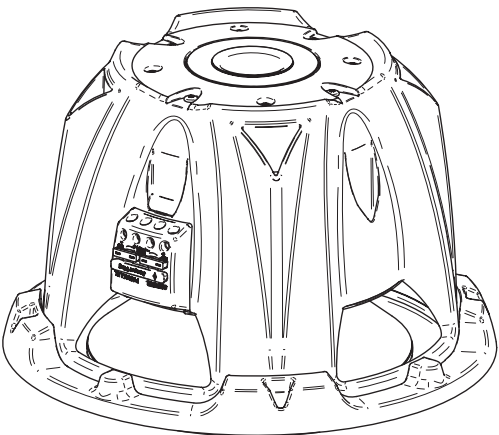
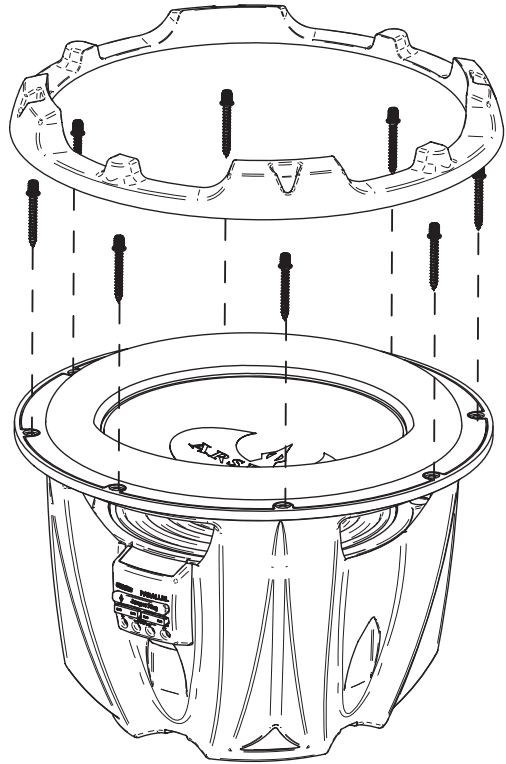
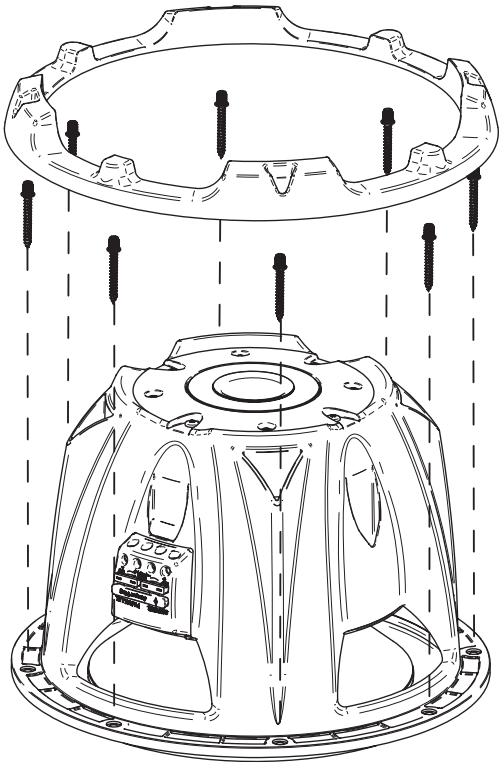
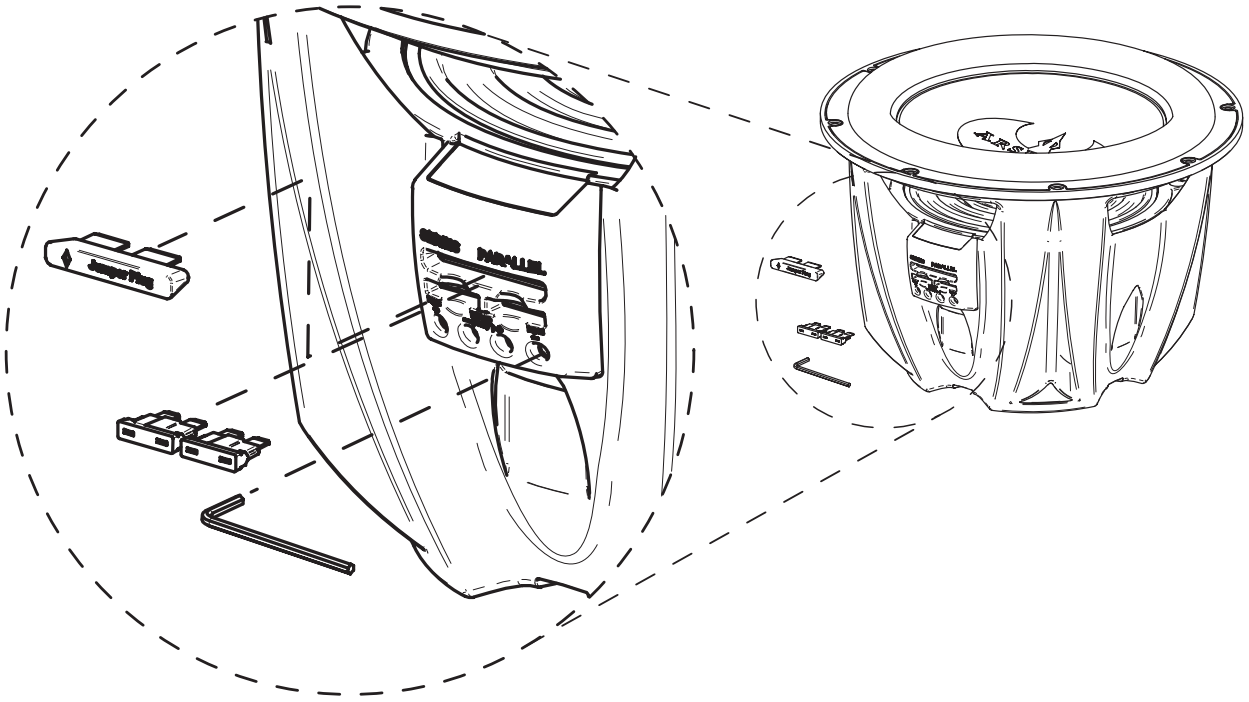

TO OUR VALUED CUSTOMER _____

THANK YOU FOR PURCHASING THIS JVC PRODUCT.
WE WANT TO HELP YOU ACHIEVE A PERFECT EXPERIENCE.

**NEED HELP ON HOW TO HOOK UP?
NEED ASSISTANCE ON HOW TO OPERATE?
NEED TO LOCATE A JVC SERVICE CENTER?
LIKE TO PURCHASE ACCESSORIES?**

JVC[®] IS HERE TO HELP!
TOLL FREE: 1(800)252-5722
<http://www.jvc.com>

Remember to retain your Bill of Sale for Warranty Service.

_____ **Do not attempt to service the product yourself** _____

Caution

To prevent electrical shock, do not open the cabinet.
There are no user serviceable parts inside.
Please refer to qualified service personnel for repairs.

JVC

